

Plans for an

# Advanced Propane Combustion Potato Cannon



Disclaimer - The following material is for educational/entertainment purposes only. I am in **no way** responsible for your actions, including damage to property and/or personal injury or death, should you make a cannon. Please keep in mind that these cannons can be very dangerous and should be given the same respect as a firearm. Bear in mind that this cannon will easily shoot a potato through ½" plywood at 25 yards! It is your responsibility to check the legality of "spud guns" in your area! The ATF does not classify them as firearms, but local laws may vary. Potatoes are the only "ammo" to be used. Some information on the legality of "spud guns" in your area can be found here: [http://en.wikipedia.org/wiki/Spud\\_gun\\_legality](http://en.wikipedia.org/wiki/Spud_gun_legality)

Remember, a little common sense goes a long way.

## Features

- Operates on propane or MAPP gas cylinders, eliminating the need for messy aerosol cans.
- Precision combustion gas metering, and electronic gas mixing system for nearly 100% reliable combustion, fast re-fire rates, and consistent power.
- Electronic push-button firing uses an ultra reliable 30,000 Volt spark generator with multi point ignition for optimum combustion.
- Built in safety switch to prevent accidental misfires.
- Calculated and extensively tested CCV:BV (Combustion Chamber Volume : Barrel Volume) for optimum performance.
- Compatible with both Propane, and the more powerful MAPP gas.
- Fast and easy barrel removal system for easy transportation and storage.
- Can be breech or muzzle loaded, breech load does not require a ram-rod to reload!
- Built in potato cutter for easy breech loading.
- Quick Vent valve on combustion chamber allows for fast and easy ventilation of combustion products for fast re-fire rates.
- Very visually intriguing, they get interest from everyone who sees them!
- Modularity and easily customizable design allow you to add your own features, like laser sights, different grip systems, different barrel sizes, expanded barrels and combustion chambers, tripods, remote firing system, and more...

# Index

- **Introduction** ..... 4
- **Required Materials List** ..... 6
- **Construction/Fabrication Stage** ..... 8
  - Combustion Chamber Construction ..... 8
  - Barrel Construction ..... 12
  - Quick Vent End Cap Construction ..... 15
  - Storage Pod Construction ..... 16
  - Gas Meter Tank Construction ..... 19
  - Cannon Handle Construction ..... 20
  - Gas Metering System Construction ..... 29
  - Spark Strip Construction ..... 31
  - Forearm Cover Construction ..... 31
  - Front Grip Construction ..... 32
- **Assembly/Fitting Stage** ..... 33
  - Combustion Chamber Assembly ..... 33
  - Barrel Assembly ..... 37
  - Electronics Pod Assembly ..... 40
  - Cannon Final Assembly ..... 43
- **Cannon Operation and Safety** ..... 53
  - Safety ..... 53
  - Loading and Firing ..... 53
  - Troubleshooting ..... 54

# Introduction

I will begin by saying that this highly advanced potato cannon is far above and beyond the average cannon you may have seen used, or have seen guides on how to build before. I have spent countless hours designing and testing the one touch gas metering system used on this cannon, I assure you that there is no faster, easier to use, more accurate gas metering system available! The ignition system used is a high voltage battery powered spark generator, no more clicking grill buttons several times to get the cannon to fire. Modular design allows for easy change out of components, and easy breakdown for transportation and storage. For example, you can have multiple different lengths and diameters of barrels, all which will mount to the same combustion chamber, gas, and ignition assembly using Cam-Lock quick connectors. You can also change out the back end caps of the combustion chamber for different purposes, such as to add an extension for greater volume, or a sealed cap for show purposes. This cannon is designed for breech loading with a built in potato cutter on the breech of the barrel, no more ramrod to carry! The cannon uses a quick vent 2" ball valve to rapidly vent spent combustion gases, allowing for quick re-fires.

The construction level of this build is by no means easy; it will take a lot of time and a fair amount of skill to complete. Do not expect this to be something you can construct in a few hours, if that is what you are looking for there are multiple websites out there that will instruct you how to build a basic potato cannon for free.

You will need to have some basic tools such as: a saw for cutting PVC, a hack saw will work but a miter and/or table saw would be much better, a drill and bits, wire cutters/crimpers, a Dremel or Rotozip would be handy but not required, sandpaper, 1/8" NPT tap, 10-24, and 8-24 or similar taps, wrenches, screwdrivers, etc. The more tools that you have, the easier it will be to construct the cannon

You will need to have some basic tool and fabrication skills such as, being able to use a hand saw and miter box, or miter saw, be able to drill and tap holes, be able to glue large PVC pipe and fittings, be able to cut, strip, and terminate wire. You must know how to read and understand basic electrical diagrams, and construction drawings. You will need to be creative, if I accomplished a task with a tool you don't have, you may need to come up with a creative solution to achieve the final result. You will also need to have the skill to paint the cannon when complete if you wish to do so.

If you are not familiar with gluing PVC, practice first, you must be good before attempting these large fittings. Dry fit connections and mark insertion depths with a pencil before starting to glue. Remember to use primer and plenty of glue on both pieces being glued, twist the fittings as they are inserted, and work fast! Hold it for a bit once it is inserted; it likes to back out if you let it go before the glue sets up some. Don't get glue on threads, it will ruin them. Read the directions on the cans of primer and PVC cement before you begin, and remember to practice some first. I also like to clean up the excess glue on all fittings after assembly with a paper towel, be sure to do this before it dries completely to make it easier to sand and prep for paint. If you need to know more on this subject, do an internet search for "how to glue PVC", this should get you going in the right direction.

I will offer my opinion on “pressure rated” (Schedule 40) or “dwv” (drain, waste, vent) PVC. I will **always** use “pressure rated” PVC for the main section of the combustion chamber, and end caps. I usually use “pressure rated” PVC for the barrel and other fittings, but sometimes use “dwv” for barrels of odd sizes, or for some fittings if “pressure rated” is not available. In general, try hard to find “pressure rated” PVC, it is just safer. To identify “dwv”, look for that stamp somewhere on it. Do not use cellular core PVC pipe for combustion chambers, if it is cellular core, it has to be marked on the pipe. Pressure rated pipe usually has the rated pressure stamped on it, as well as “Schedule 40” or “80”.

With all of that said, let’s get started!

## Required Materials List

Material	Purpose/Comments	Available from	Links
PVC pipe and fittings	Barrel, combustion chamber, gas tank, handle, etc.	Plumbing supply stores Home improvement stores Local hardware stores Grainger.com USPlastics.com	<a href="http://www.usplastic.com/catalog/default.aspx?catid=728&amp;parentcatid=681">http://www.usplastic.com/catalog/default.aspx?catid=728&amp;parentcatid=681</a>
2" PVC ball valve – Slip X Slip	Quickly vent combustion gasses.	Hardware stores Home improvement stores - \$12.91 Plumbing supply stores	<a href="http://www.homedepot.com/h_d1/N-5yc1v/R-202369989/h_d2/ProductDisplay?langId=-1&amp;storeId=10051&amp;catalogId=10053">http://www.homedepot.com/h_d1/N-5yc1v/R-202369989/h_d2/ProductDisplay?langId=-1&amp;storeId=10051&amp;catalogId=10053</a>
Cam and groove "Camlock" fittings	Attach barrel to combustion chamber. Available in aluminum, poly, and stainless. I used aluminum.	Ebay.com – Male-Female pair for \$16.50 Tractor supply Grainger.com	<a href="http://stores.ebay.com/industrialsupplybellingham">http://stores.ebay.com/industrialsupplybellingham</a>  <a href="http://stores.ebay.com/UNIVERSAL-HOSE-AND-FITTINGS/Cam-Lock-Fittings-Aluminum-/i.html?fsub=7&amp;sid=35883411&amp;trksid=p4634.c0.m322">http://stores.ebay.com/UNIVERSAL-HOSE-AND-FITTINGS/Cam-Lock-Fittings-Aluminum-/i.html?fsub=7&amp;sid=35883411&amp;trksid=p4634.c0.m322</a>  <a href="http://www.globalindustrial.com/g/plumbing/pumps/water-trash/aluminum-camlock-fittings">http://www.globalindustrial.com/g/plumbing/pumps/water-trash/aluminum-camlock-fittings</a>
Propane tank adapter	Converts Propane tank to pipe threads to attach regulator to tank.	protanksupply.com - \$9.84	<a href="http://www.protanksupply.com/camping-propane-fittings_detail.asp?ID=3022">http://www.protanksupply.com/camping-propane-fittings_detail.asp?ID=3022</a>
¼"OD poly tubing	Gas delivery line – go with whatever color you choose.	Ebay.com – Search for "john guest ¼" tubing" Local hardware stores Home improvement stores Plumbing supply stores	<a href="http://stores.ebay.com/Aqua-Systems/Water-Tubing-/i.html?fsub=10&amp;sid=65686375&amp;trksid=p4634.c0.m322">http://stores.ebay.com/Aqua-Systems/Water-Tubing-/i.html?fsub=10&amp;sid=65686375&amp;trksid=p4634.c0.m322</a>
¼" tubing fittings	Can use the cheaper ones from home improvement and hardware stores, but the Legris brand swivel elbows are the best.	Grainger.com – 10pcs \$29.05	<a href="http://www.grainger.com/Grainger/LEGRIS-Male-Elbow-1PFA8?Pid=search">http://www.grainger.com/Grainger/LEGRIS-Male-Elbow-1PFA8?Pid=search</a>
Spark generator	Prefer the link to the right, but any battery grill igniter, or stun guns may also be used with some modification.	Ultimatespudgun.com – \$21.99 Ebay.com - ???	<a href="http://ultimatespudgun.com/30kv-igniter-p-219.html">http://ultimatespudgun.com/30kv-igniter-p-219.html</a>
Electrical wire, crimp	Wiring	Home improvement stores Local hardware stores	

on fittings, etc.		McMaster.com	
Heat shrink tubing	Insulating wiring connections. Covering wires, and hose clamps	Home improvement stores Local hardware stores McMaster.com	
Project box, switches, LED's, resistors, etc.	Wiring	RadioShack	
Red covered safety switch	Safety	RadioShack - \$4.99 Local hardware stores Ebay.com Search Ebay for "red safety switch"	<a href="http://www.radioshack.com/product/index.jsp?productId=2062493">http://www.radioshack.com/product/index.jsp?productId=2062493</a>
10-24, and 8-24 Threaded studs, screws and nuts	Spark strip system, and fan electrical contacts. I use all stainless steel, but it is not required	McMaster.com Local hardware stores Home improvement stores Make your own studs by cutting off screw heads	<a href="http://www.mcmaster.com/#threaded-rods-and-studs/=d4ybky">http://www.mcmaster.com/#threaded-rods-and-studs/=d4ybky</a>
Mead MV-10 Three Way Valve	Gas Injection System	MSCDirect.com – \$24.84 Ebay.com – Search eBay for "Mead MV10" – user "PLC Center" - \$19.10	<a href="http://www1.mscdirect.com/CGI/NNSRIT2?PMPXNO=3417546&amp;PMTERM=">http://www1.mscdirect.com/CGI/NNSRIT2?PMPXNO=3417546&amp;PMTERM=</a>  <a href="http://stores.ebay.com/PlcCenter-Surplus-Industrial? trksid=p4340.l2563">http://stores.ebay.com/PlcCenter-Surplus-Industrial? trksid=p4340.l2563</a>
1/8" MPT brass pipe nipples and fittings	Gas Injection System	McMaster.com Local hardware stores Home improvement stores	
Push button SPST Ignition switch	Trigger switch	RadioShack -\$2.69 Home improvement stores Local hardware stores	<a href="http://www.radioshack.com/product/index.jsp?productId=2062510">http://www.radioshack.com/product/index.jsp?productId=2062510</a>
Teflon tape	Sealing threads	Plumbing supply stores Home improvement stores Local hardware stores	

# CONSTRUCTION/FABRICATION STAGE

## Combustion Chamber Construction:

Please excuse the fact that all photos are of a completed, disassembled cannon. This was done because MANY prototypes were constructed, and the cannon shown in the photos is the product of many months of perfecting the final design. Please follow the written instructions and use the photos for reference.

The construction of the combustion chamber begins with an 11" long section of 4" "pressure rated" PVC. You can buy in long pre cut sections, or have the guy at the store where you buy it cut it to length for you(much easier). Use whatever means you have to get an 11" long piece with nice, square cut ends. You will also need: 1- 4" Slip X 4" FPT fitting, 1 - 4" Slip X 4" Slip fitting, 1 - 4" Slip X 3" Slip reducer bushing, and 1- 3" Slip X 3" FPT fitting.

Here is a simple drawing to illustrate the basic construction of the combustion chamber.

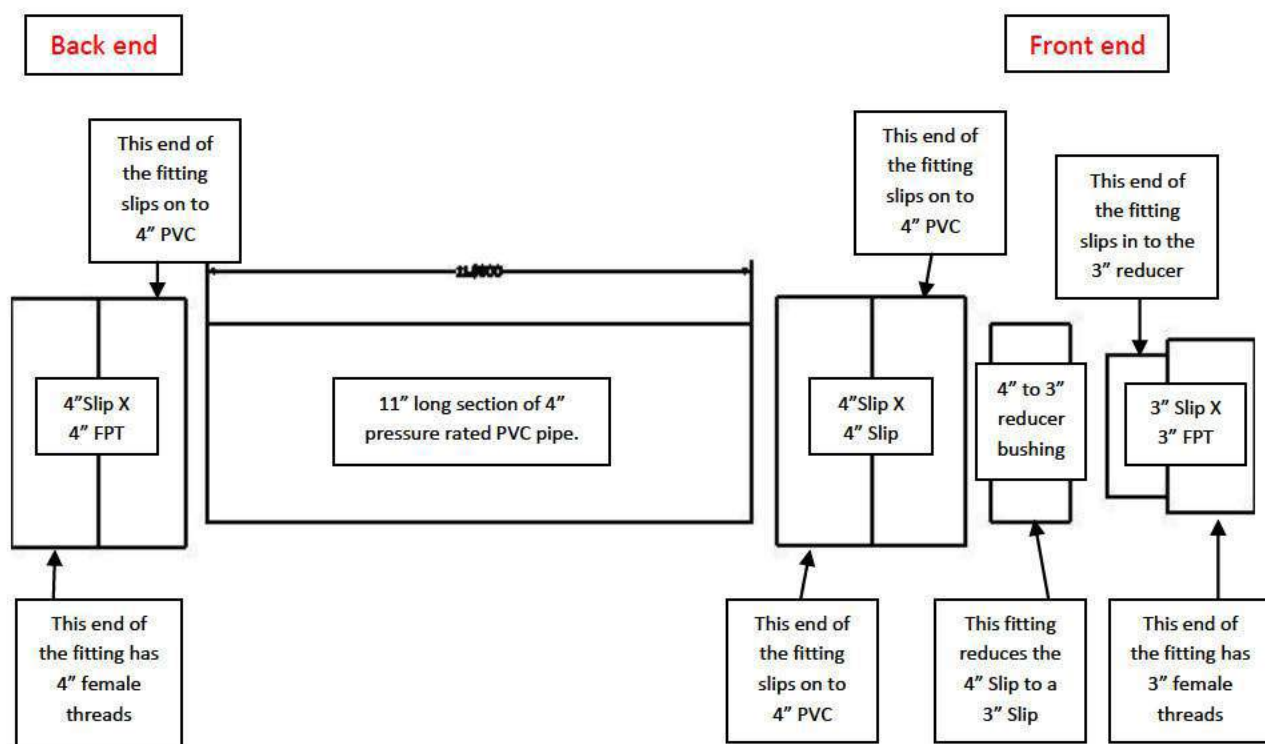

On the back end of the combustion chamber, you will need to glue a 4" Slip X 4" FPT (Female Pipe Thread) fitting. See photos below each instruction for details.

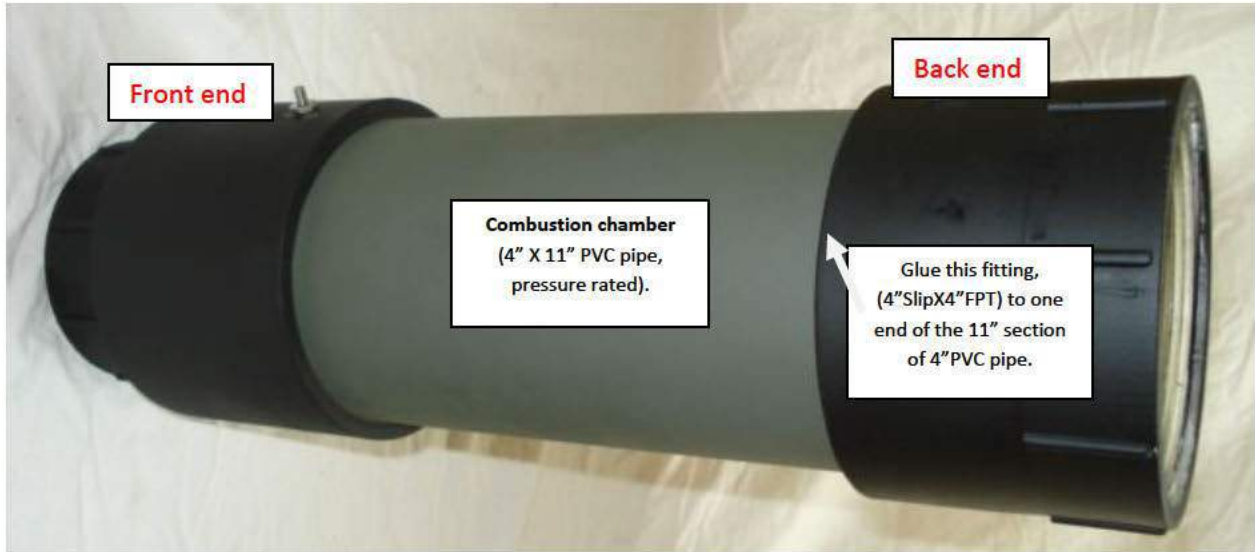

On the front end of the combustion chamber, you will need to glue a 4" Slip X 4" Slip fitting (this is a 4" pipe slip coupler, which would be used for coupling 2 sections of 4" pipe). Next, a 4" to 3" reducer bushing will be glued in to the 4" Slip fitting and reduce it to a 3" Slip fitting. Finally you will need to glue a 3" Slip X 3" FPT (Female Pipe Thread) to the reducer bushing installed in the previous step.

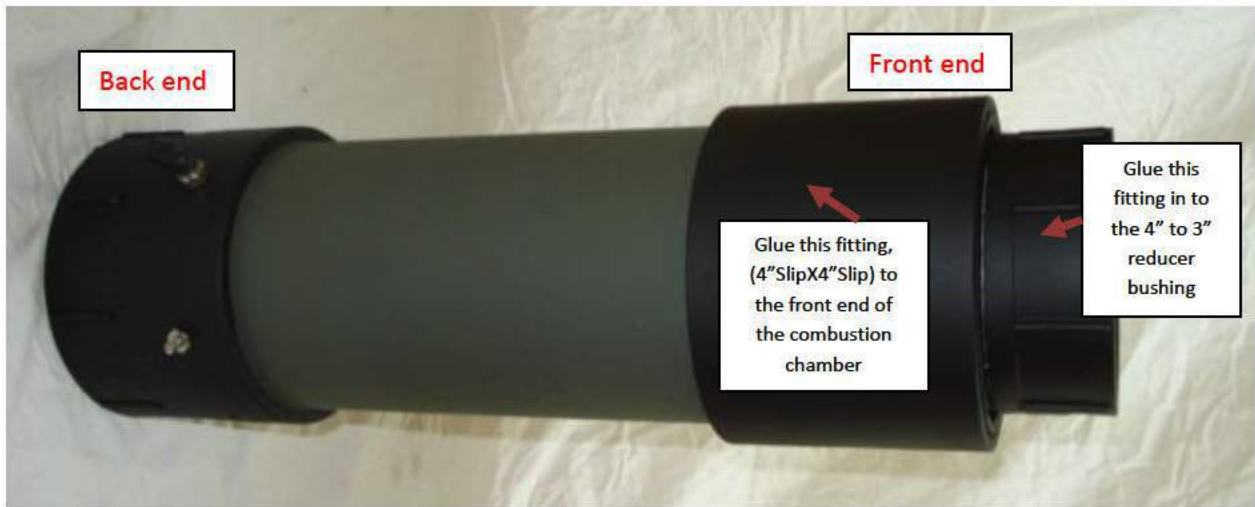



Your basic combustion chamber section is now complete and should look remotely like the one shown in the above pictures (minus the paint, plumbing, and electrical fittings which will be installed later).

Now you will need to create the threaded holes for the spark strip, fan, and gas line. We will begin with holes for the spark strip. You will need two holes, one in the front end slip fitting, and one in the back end slip fitting. When drilling all holes, I like to make sure to drill thru two layers, that is, thru the fitting and the pipe for maximum strength.

Drill the first hole for the spark strip in the front end, about 3" in from the outside edge of the 4" Slip fitting using a 5/32" drill bit, approximately as shown in the photo below. To ensure your next hole is in line, stand the combustion chamber on the back end and thread a piece of thin, light weight thread out the top hole from the inside of the chamber, tie a small weight on the end of the thread on the outside, let the weight hang while holding the other end of the string inside of the chamber. Make your mark in line with the hanging thread at a distance of about 10" from the top hole. Then, drill the second hole for the spark strip in the back end fitting at a center-to-center distance of about 10" from the hole drilled in the previous step.

Tap both drilled holes all the way thru with a 10-24 tap. (Tapping tips: ensure you tap perpendicular to the surface, tap by hand or very slowly with a tap in a drill, apply a small amount of white lithium grease to the tap, and just be gentle.)

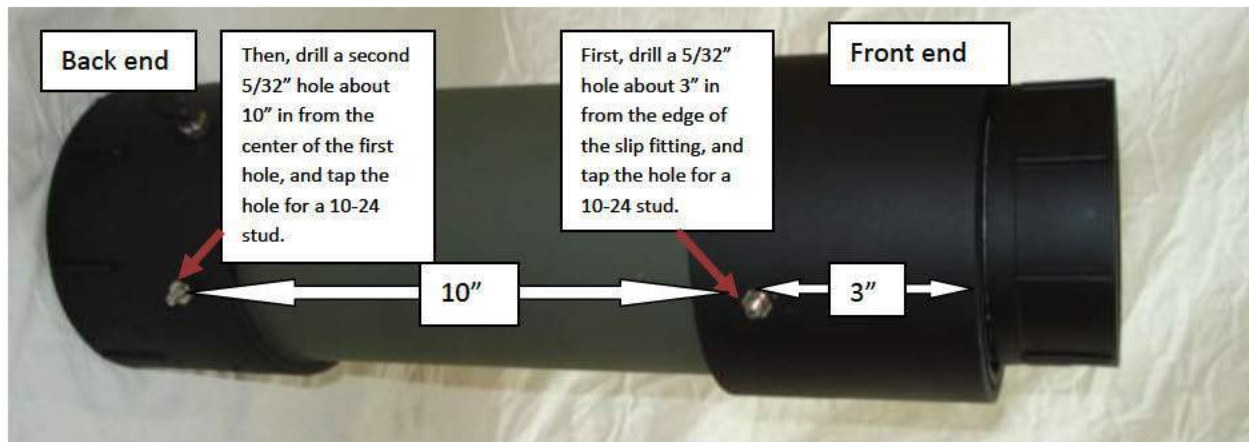

You will now need to drill and tap a hole for the gas injection fitting. This hole will be on the back end of the combustion chamber, about 3" in from the back edge of the fitting, and a circumferential distance of about 4" clockwise from the hole drilled for the spark strip when viewed looking down as shown in the photo below. Drill the hole using a 5/16" drill and then tap the hole using a 1/8" NPT tap.

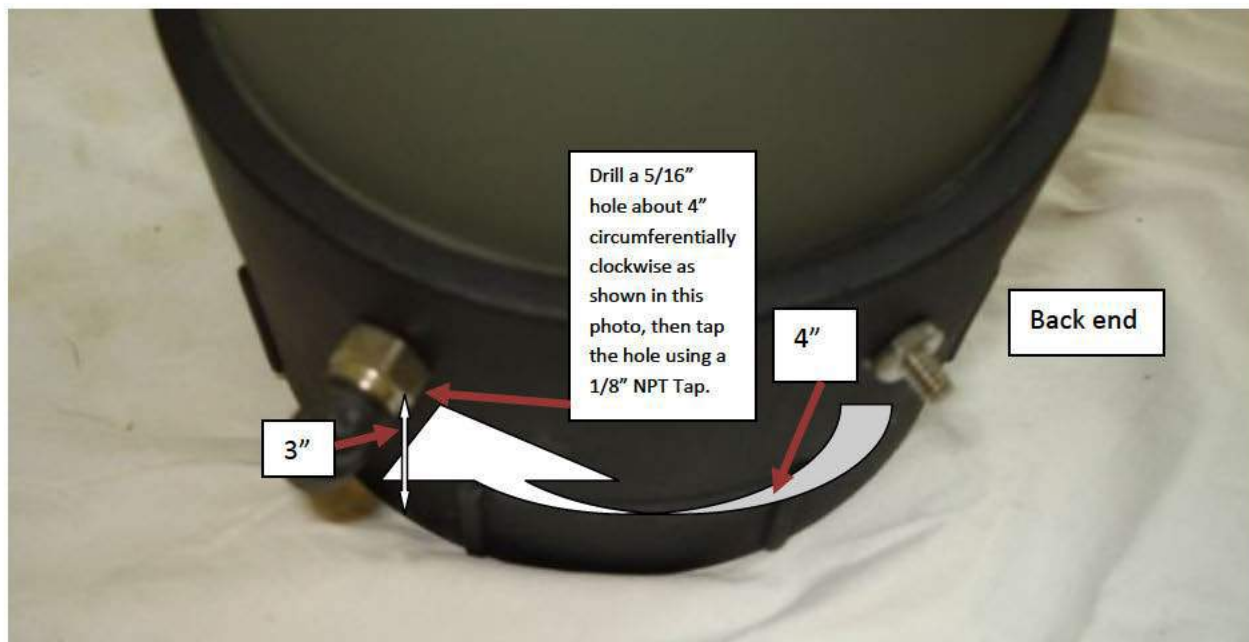

Finally, you will need to drill two holes for the internal combustion chamber fan. Note the location of these two holes in relation to the gas injection fitting (left hand edge of the combustion chamber in the photo below) hole drilled in the previous step. These holes will be on the back end of the combustion chamber, about 3" in from the back edge of the fitting, and a circumferential distance of about 4" counter-clockwise from the hole drilled for the spark strip when viewed looking down as shown in the

photo below. Drill the two holes as shown in the photo below, about  $\frac{5}{8}$ " apart using a  $\frac{9}{64}$ " drill and then tap the holes using an 8-32 tap.

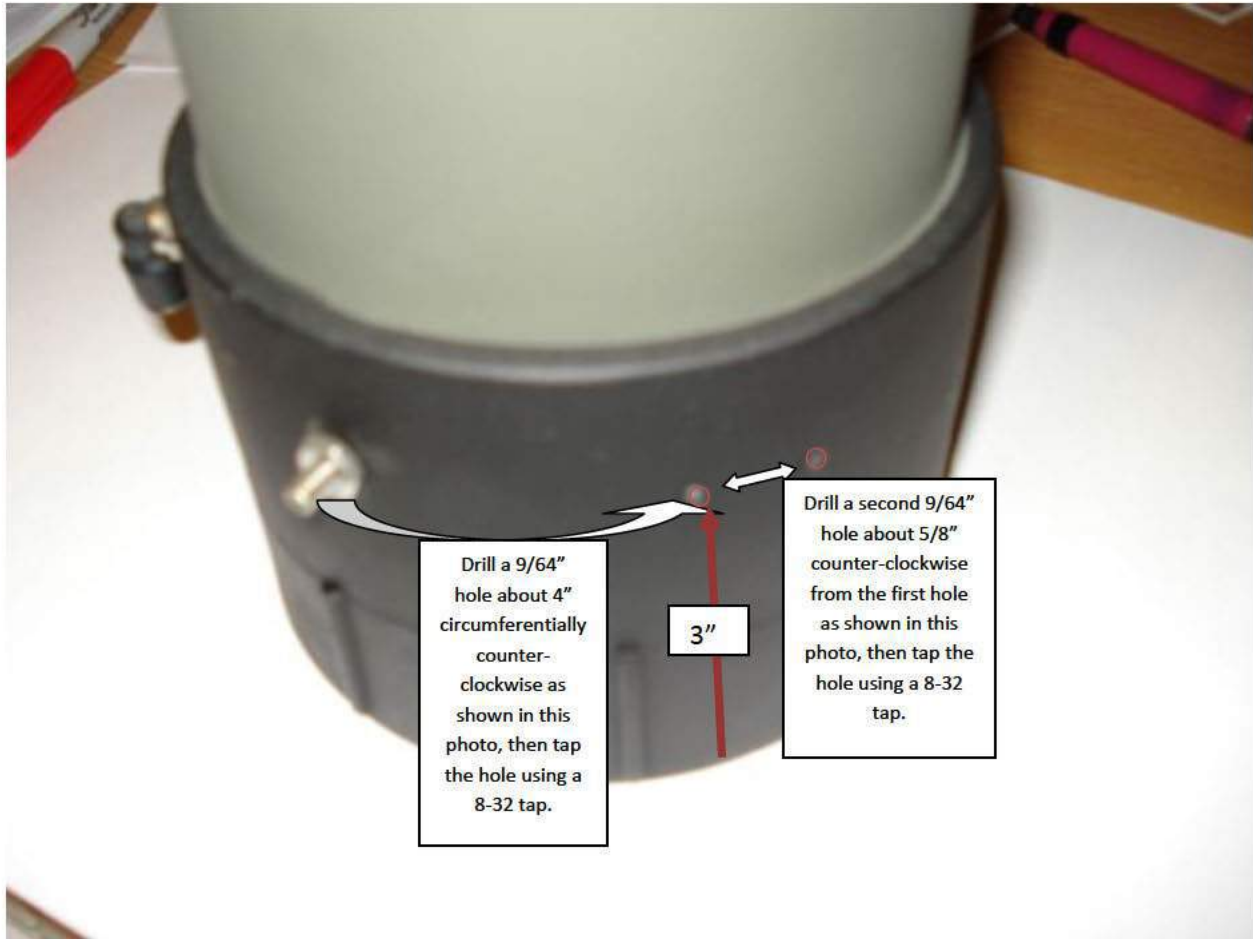

This concludes the work on the combustion chamber for now; we will resume work with it during the cannon assembly stage. Now is a good time to paint your cannon with the color scheme of your choice, if you so wish. (Be sure not to paint the large PVC fitting threads, as this will make them difficult to operate.)

#### Barrel Construction:

The construction of the barrel begins with a 36" long piece of  $1\frac{1}{2}$ " PVC pipe. I use this barrel because it gives the best performance of any combination I have tried. You can use different diameters and lengths of barrels, but should make to match the volume of the barrel I am demonstrating, or adjust the combustion chamber volume accordingly. You will also need: 1 - 3" to  $1\frac{1}{2}$ " reducer bushing, and 1 - 3" slip X 3" MPT fitting.

Here is a simple exploded drawing to illustrate the basic construction of the barrel.

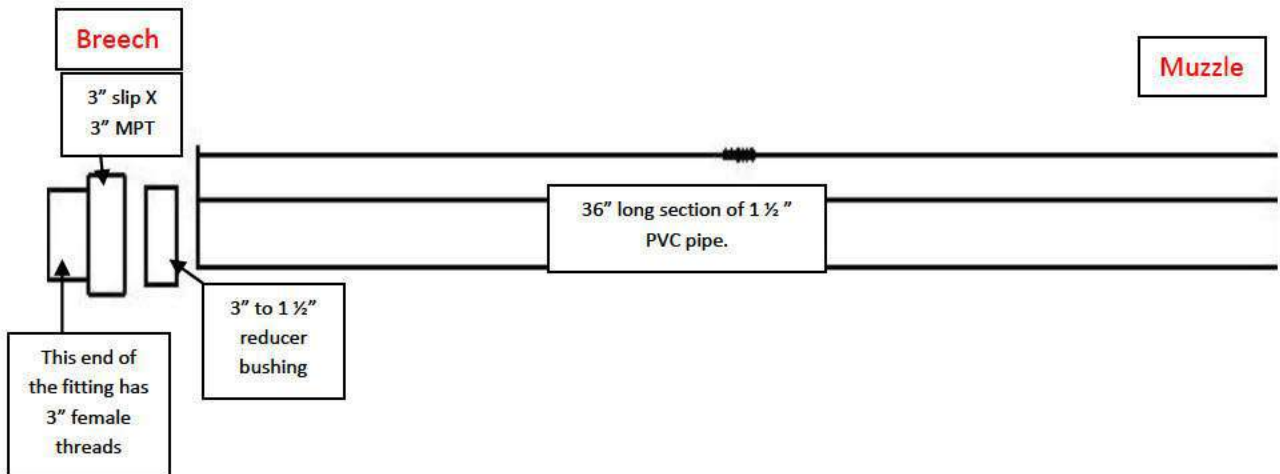

Here is a simple drawing of the barrel assembly to show the location of the fittings to allow for breech loading.

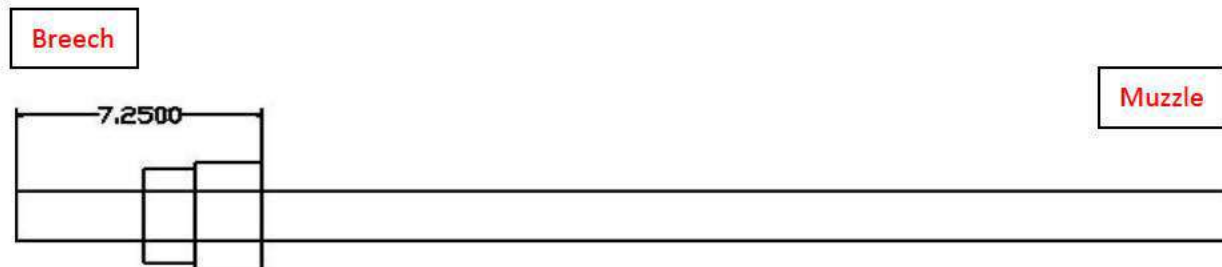

The first step is to prepare the 3" to 1 1/2" reducer to allow the PVC barrel to pass freely thru it. As it was purchased, it has a lip in the back that only allows the PVC pipe to be pressed in so far. Try it and you will see that the PVC pipe will not pass thru the fitting. You need to use a file, sandpaper, dremel, or whatever tool you prefer to remove this lip that is stopping the PVC pipe from passing thru the fitting. Don't worry about removing too much material, I actually like to chamfer this a little to allow the PVC pipe to slide over the barrel fairly easily. Once you have this lip removed, try to fit it over the barrel, it should be able to slide on to the pipe about 7" by hand. If it is too tight, you might try sanding the inside diameter of the fitting slightly.

You will now want to sharpen the breech end of your barrel, because it is easier now than after your barrel is complete. Pick an end to sharpen, then using sandpaper, a belt sander, file, router, or whatever tool you prefer, grind a potato cutting chamfer on the breech end of the PVC pipe. Sharpen by removing

material from the outside edge of the pipe to create a cutting edge, sand smooth until it easily cuts a potato shoved in it.

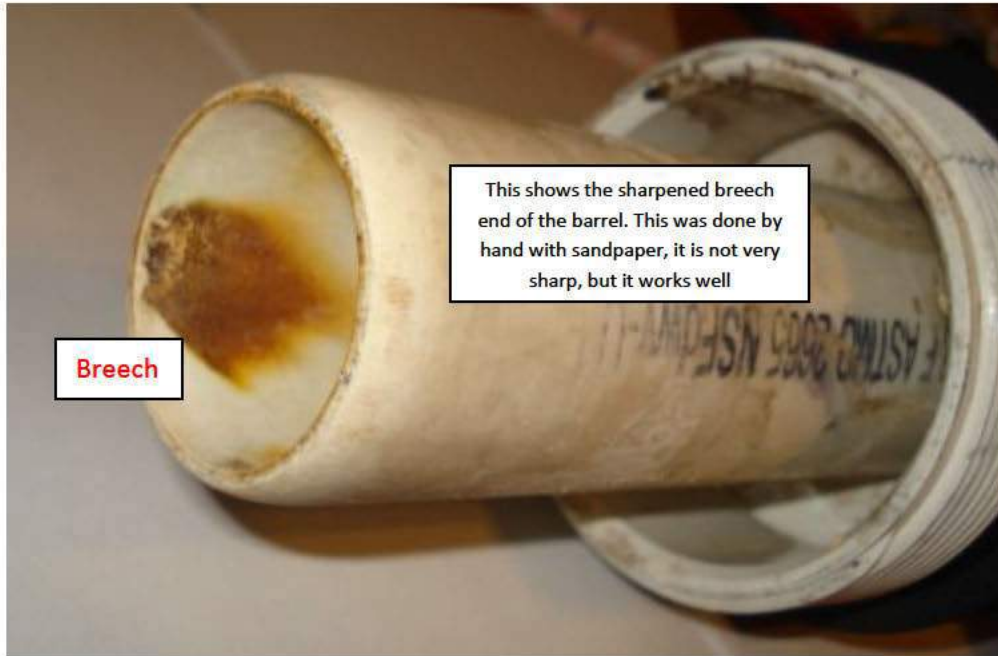

Next you will glue this reducer fitting on to the barrel. First, make a mark about  $7\frac{1}{4}$ " in from the breech end of the barrel (the end you just sharpened). Ensure that you have the 3" to  $1\frac{1}{2}$ " reducer oriented correctly, so that you can glue the 3" slip X 3" MPT (male pipe thread) over it from the breech end. Now apply primer to the barrel, from the breech end to the  $7\frac{1}{4}$ " mark, and apply primer to the inside of the modified reducer fitting. This part is slightly tricky, you need to use PVC glue on the barrel, from breech end to the  $7\frac{1}{4}$ " mark, and inside the fitting, then quickly press the fitting on to the barrel with a twisting motion until the front of the fitting reaches the  $7\frac{1}{4}$ " mark on the barrel. Hold about 30 seconds while it dries. Wipe off all of the excess PVC glue right away. Next you will glue the 3" slip X 3" MPT fitting on to the reducer fitting you just glued on to the barrel. This is also shown in the above photo.

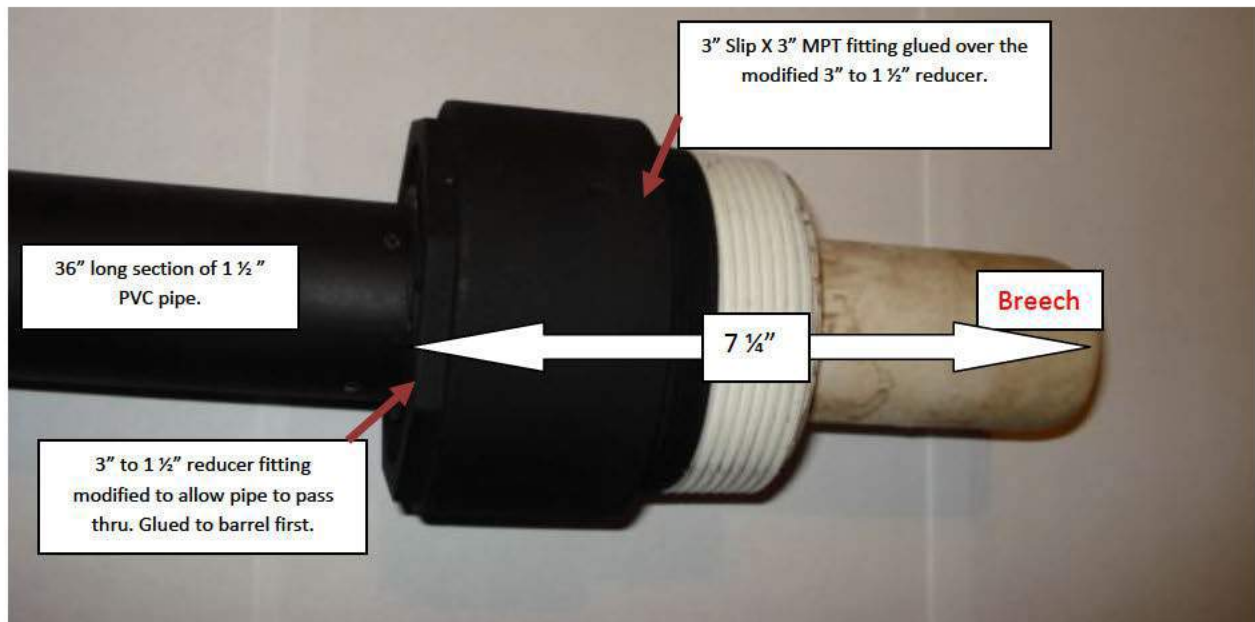

This concludes the work on the barrel assembly for now; we will resume work with it during the cannon assembly stage. Now is a good time to paint your cannon with the color scheme of your choice, if you so wish. (Be sure not to paint the large PVC fitting threads, as this will make them difficult to operate.)

#### Quick Vent End Cap Construction:

The construction of the end cap begins with a 4" Slip X 4" MPT (male pipe thread) fitting that will screw in to the back end of the combustion chamber. I always test these male threads at the store with a good female fitting because I have gotten a few that are slightly out of round and just don't operate well, just a word of advice. You will also need: 1 - 4" pipe to 2" pipe reducer bushing, 1- 2" PVC ball valve, 1 - short piece of 2" PVC pipe (about 2 1/4").

Start by measuring the length of 2" PVC pipe you will need by measuring the depth of the ball valve to the pipe stop, plus the depth of the 4" to 2" reducer bushing to the pipe stop. Mine came out to be about 2 1/4". Cut your section of 2" PVC pipe to the length you need, and then glue it in to one end of the 2" PVC ball valve.

I cut off some of the extra PVC on the other end of the ball valve using a miter saw at this point. I did this to shorten the overall length of the cannon, you can do this if you wish, but it is not needed.

Next, you will glue the short section of 2" PVC pipe sticking out of the ball valve in to the 4" to 2" reducer bushing. Finally, you will glue the 4" to 2" reducer bushing in to the 4" Slip X 4" MPT fitting. The photo and comments below illustrate the work in the above steps.

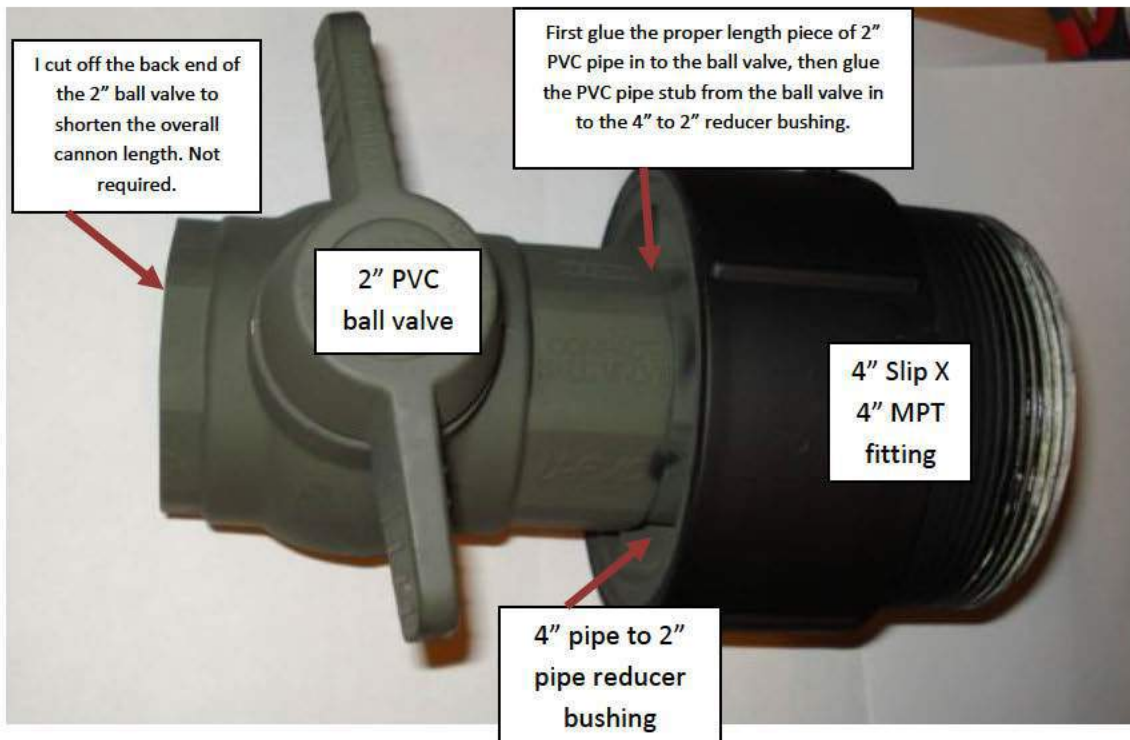

This concludes the work on the Quick Vent End Cap assembly for now; we will resume work with it during the cannon assembly stage. Now is a good time to paint your cannon with the color scheme of your choice, if you so wish. (Be sure not to paint the large PVC fitting threads, as this will make them difficult to operate.)

### Storage Pod Construction:

You will need to build 2 of these; one will become your propane storage pod, the other will become your electronics storage pod.

The construction of the pods begins with 2 - 8 1/2" sections of 3" PVC pipe. You will need to glue a 3" PVC end cap on to one end of each 8 1/2" piece of PVC pipe. You will then glue a 3" Slip X 3" FPT fitting on to the other end of each tube. You should end up with two pods that look similar to the one shown in the photo below.

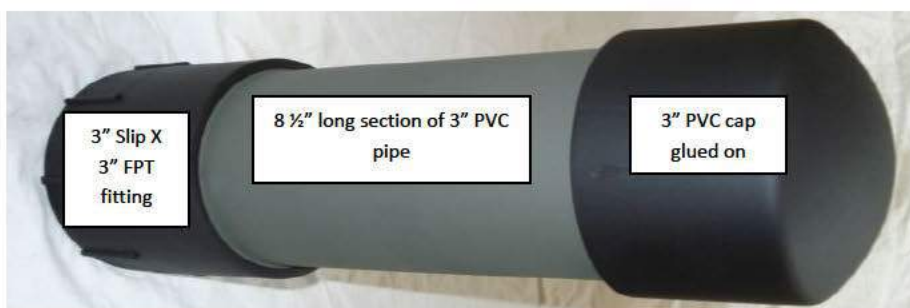

The first of the two pods just constructed will be used for a propane storage pod. The only thing you will have to do is modify a 3" PVC male threaded end cap by cutting out the center to allow for the propane bottle to protrude thru. I used a miter saw to cut out the square block in the PVC cap flush with the top of the cap. A drill and jig saw, hacksaw, or dremel would also work, use whatever you think you can make work best. The photo below shows the two caps required for the Storage Pods.

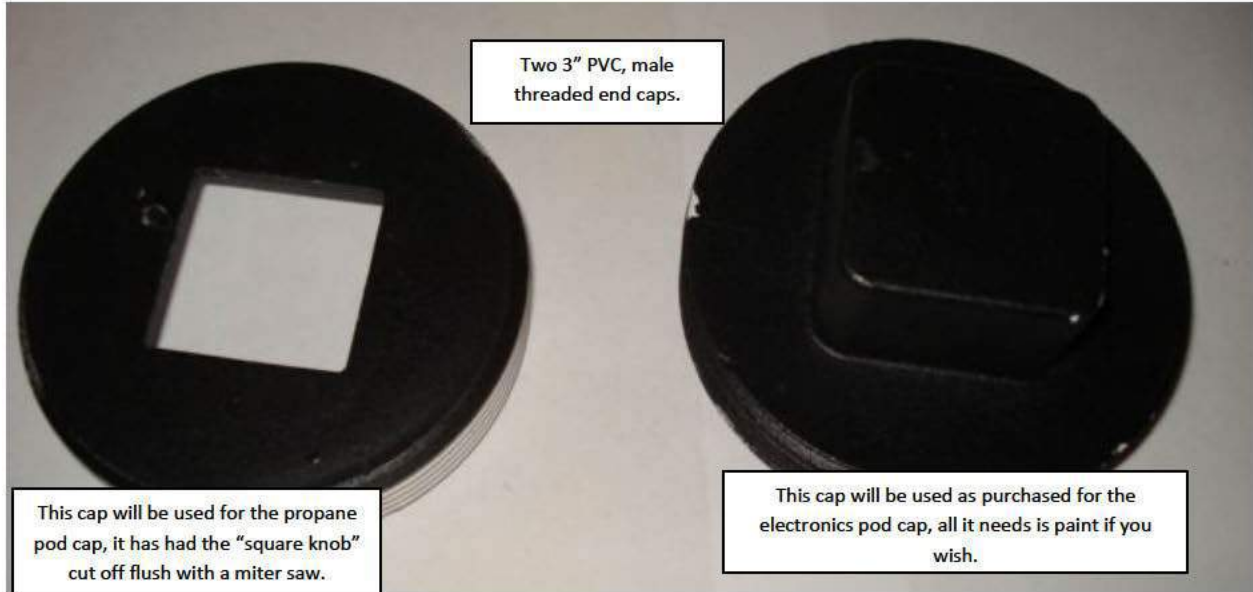

The second pod will become the electronics storage pod. Using the second pod constructed above, you will need to add several holes, and mount a small project box to the side. This construction can be done in many ways, you could eliminate the project box and mount switches and LED's directly in the PVC pipe, you could use a larger project box, etc... I will show photos below to illustrate how I constructed my electronics pod, but there are countless options. You will need to have the 9 volt batteries, spark generator, and wiring inside of the electronics pod. The project box will house the switches, and the LED's.

First you will need to drill two small holes a couple of inches apart for the spark strip leads, another larger hole (at least 1/2"-bigger=easier) to pass wires and connectors, two small holes to mount the project box with two small self tapping screws, and one large hole through the project box and PVC pipe to pass wires and connectors through. The holes are arranged such that when the project box is mounted and the electronics pod is mounted to the combustion chamber, the spark strip lead holes will be inside the triangle formed by the combustion and the two pods. See the photos below for details.

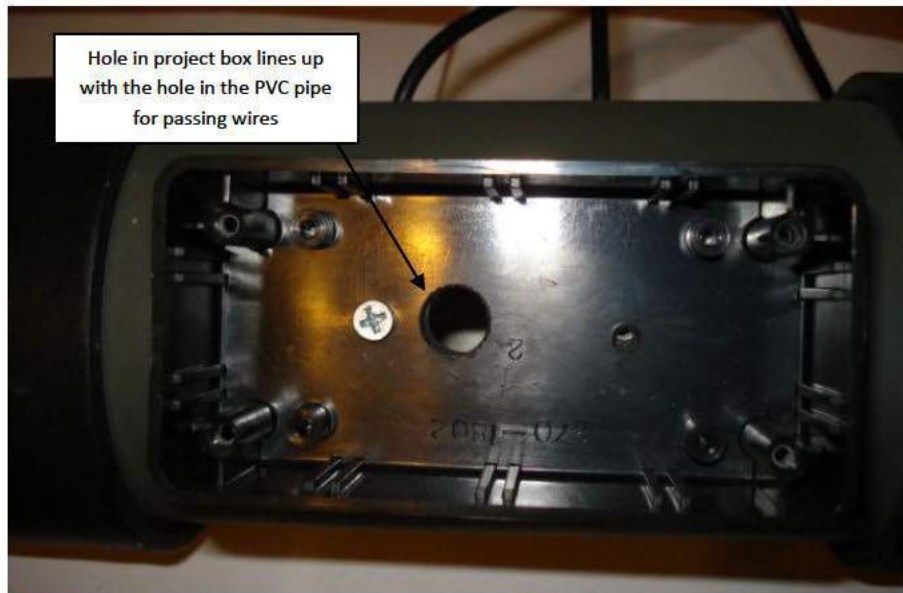
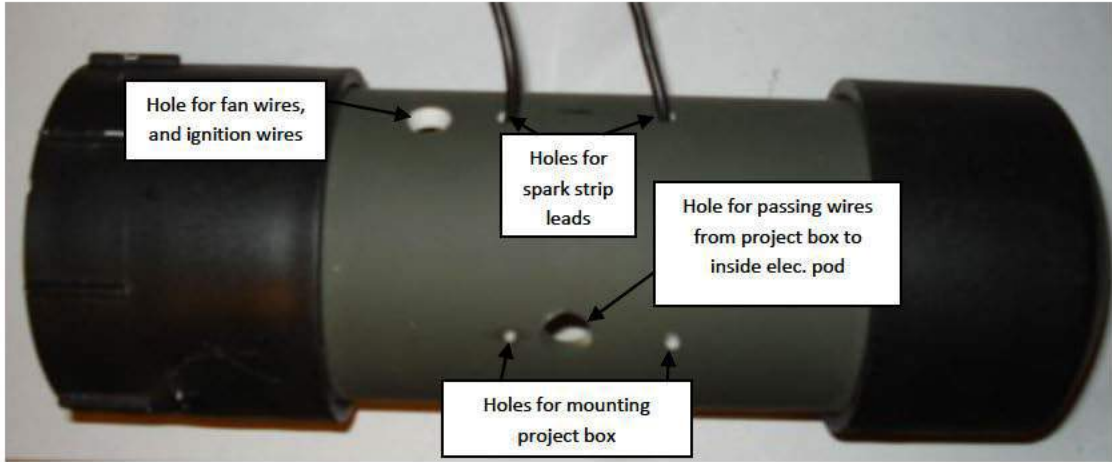

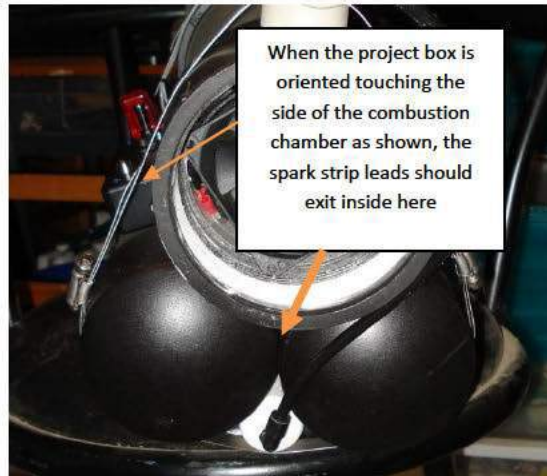

This concludes the work on the propane and electronics pod assemblies for now; we will resume work with it during the cannon assembly stage. Now is a good time to paint your pods with the color scheme of your choice, if you so wish.

#### Gas Meter Tank Construction:

The construction of the PVC gas meter tank begins with a 9 ½" long section of ¾" PVC pipe, you will also need: 2 – ¾" PVC pipe end caps, and 1- 1/8" MPT X ¼" OD hose quick connect fitting (Legris).

You will begin by drilling a 5/16" hole in the center of one of the end caps. Be careful to drill perpendicular, and right in the center, use a drill press if you have access. Now you will need to tap that hole with 1/8" female NPT threads. Next, you will need to glue the drilled and tapped end cap on to one end of the 9 ½" long piece of ¾" PVC pipe. Be careful to not get glue on the threads you just tapped. Finally, you will glue the other end cap (the one with no hole in it) on the other end of the section of ¾" PVC pipe.

Install the Legris quick connect swivel fitting in to the tapped hole, be sure to use Teflon tape to prevent leaks.

The photo and comments below illustrate the work in the above steps.

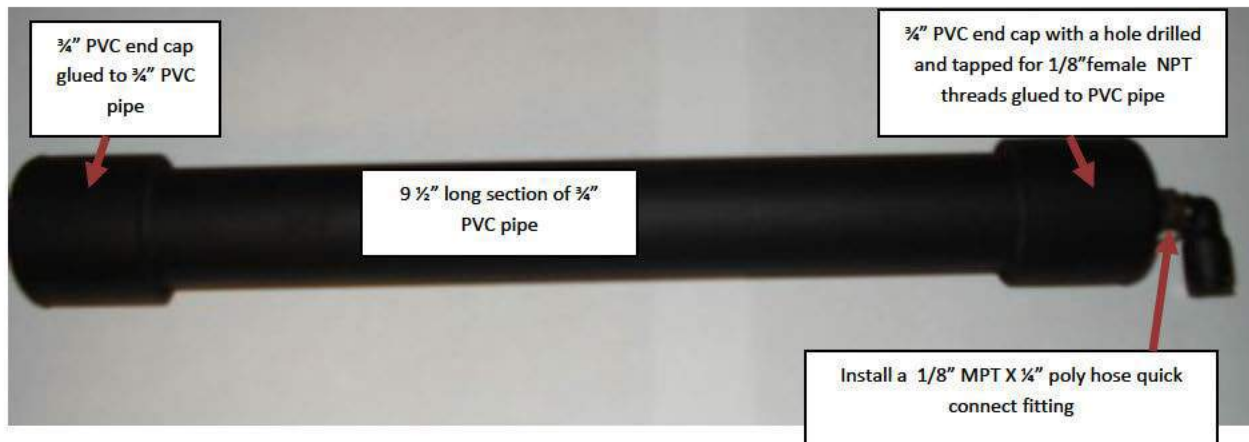

This concludes the work on the Gas Meter Tank assembly for now; we will resume work with it during the cannon assembly stage. Now is a good time to paint your cannon with the color scheme of your choice, if you so wish. (Be sure not to paint the Legris fitting.)

#### Cannon Handle Construction:

The handle for the cannon is constructed of 3/4" PVC pipe and fittings. The handle construction is one of the more difficult parts to fabricate. Two photos are shown below showing the layout of the handle parts, and how it needs to fit on the combustion chamber.



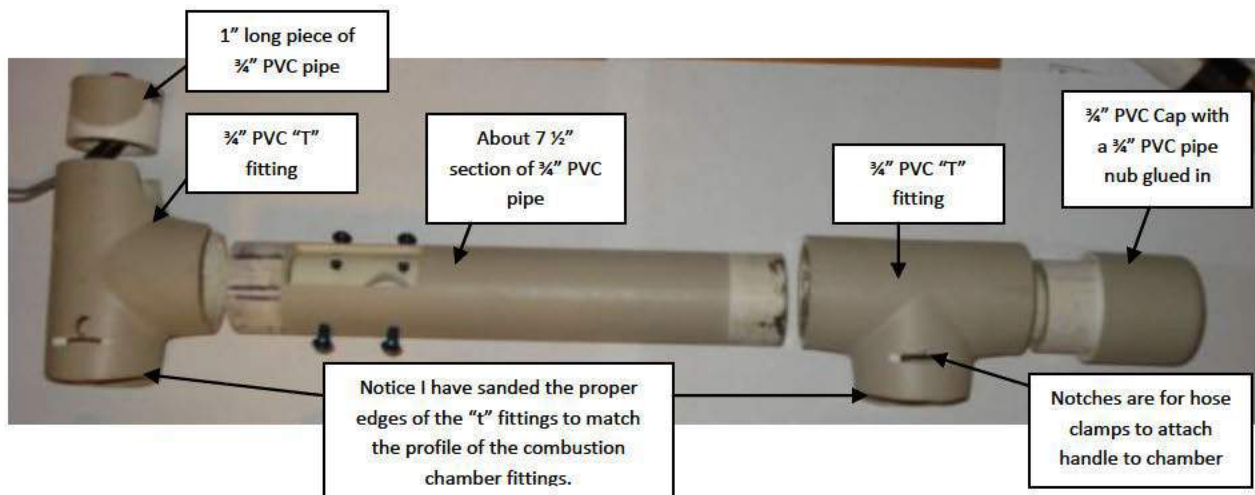

Note: Only glue the PVC pipe nub in to the cap. The disassembled joints in the photo above will remain unglued to allow for assembly and disassembly.

We will begin the construction at the back of the handle by gluing a short section of  $\frac{3}{4}$ " PVC pipe in to a  $\frac{3}{4}$ " PVC cap fitting. The piece of PVC pipe should be about  $1\frac{3}{4}$ " long, it should be measured using your  $\frac{3}{4}$ " "T" fitting such that the cap and pipe nub slip in to the "T" and leave no gap when assembled. See the top photo above for how it should fit when assembled. You will then drill an approximately  $\frac{5}{8}$ " diameter hole in the back of the PVC cap fitting as shown in the photo below.

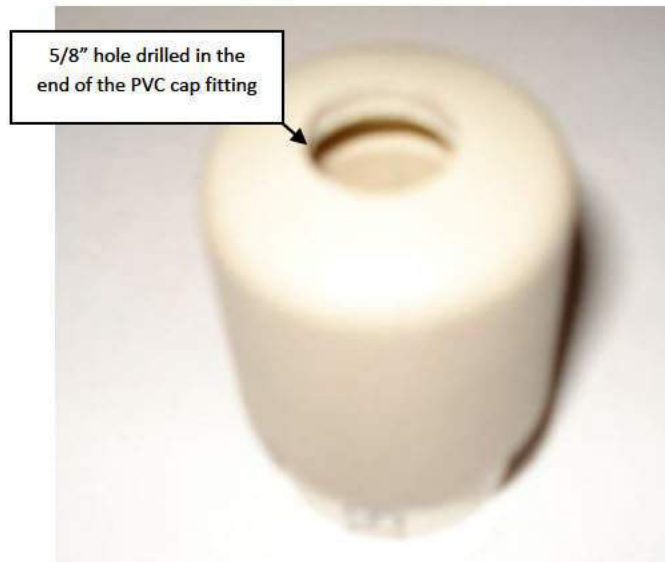

Next, we will fabricate the back "T" fitting by first forming the bottom with a curve to fit on the combustion chamber. This is not absolutely necessary, but creates a much nicer appearance. I did this by applying sandpaper to the outside of the combustion chamber fittings and sanding for a long time until the profile of the fitting matches the profile of the round fitting.

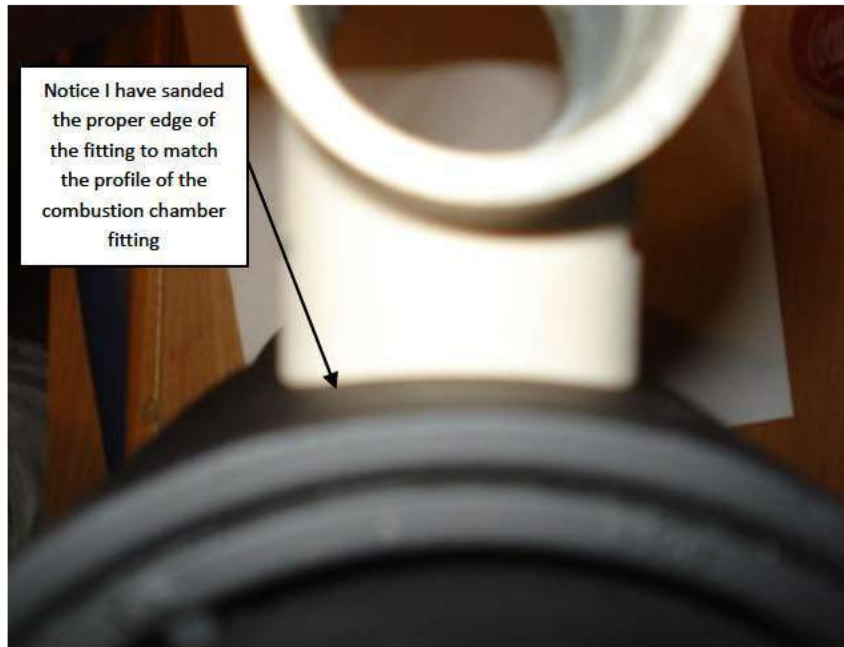

Then you will need to cut slots on both sides of the fitting to allow for the steel pipe clamp to pass through to attach the handle to the combustion chamber. I did this by marking the location about as shown in the photo below and cutting partially into the fitting with a miter saw, I then cut the inside edges out with an x-acto knife until it was wide enough to allow the hose clamp to pass through.

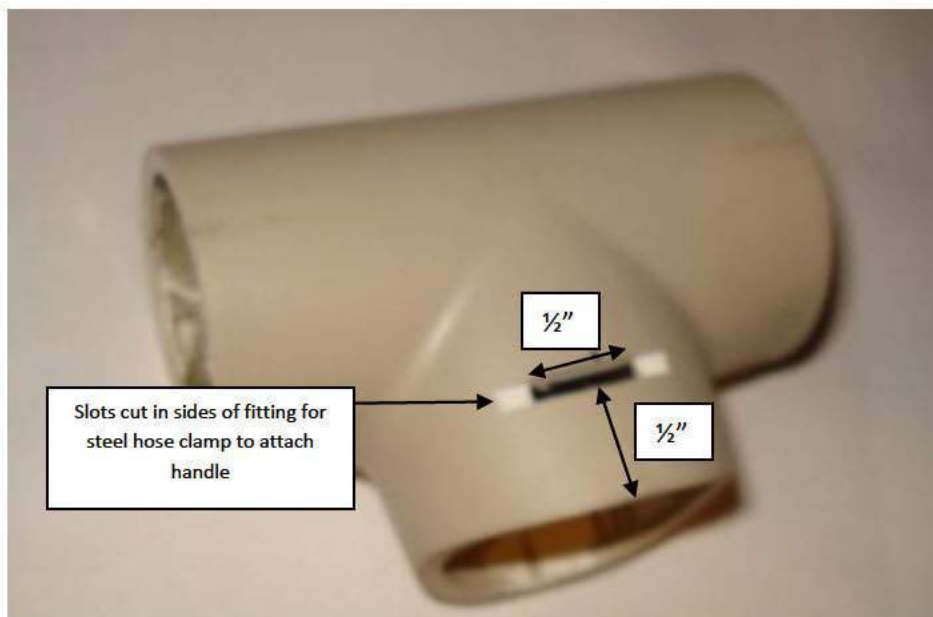

Fabricating the "T" PVC fitting for the front of the handle is next, and is similar to the back fitting you just fabricated. The difference is the orientation, notice in the photo below which edges need to be

sanded to match the profile of the combustion chamber fittings, and where the slots need to be cut for the pipe clamp. Profile the proper end of the front fitting and cut the slots using the method you used above. You will then drill an approximately  $\frac{1}{4}$ " hole on the left side of the front fitting, as shown in the photos below for wiring the trigger button.

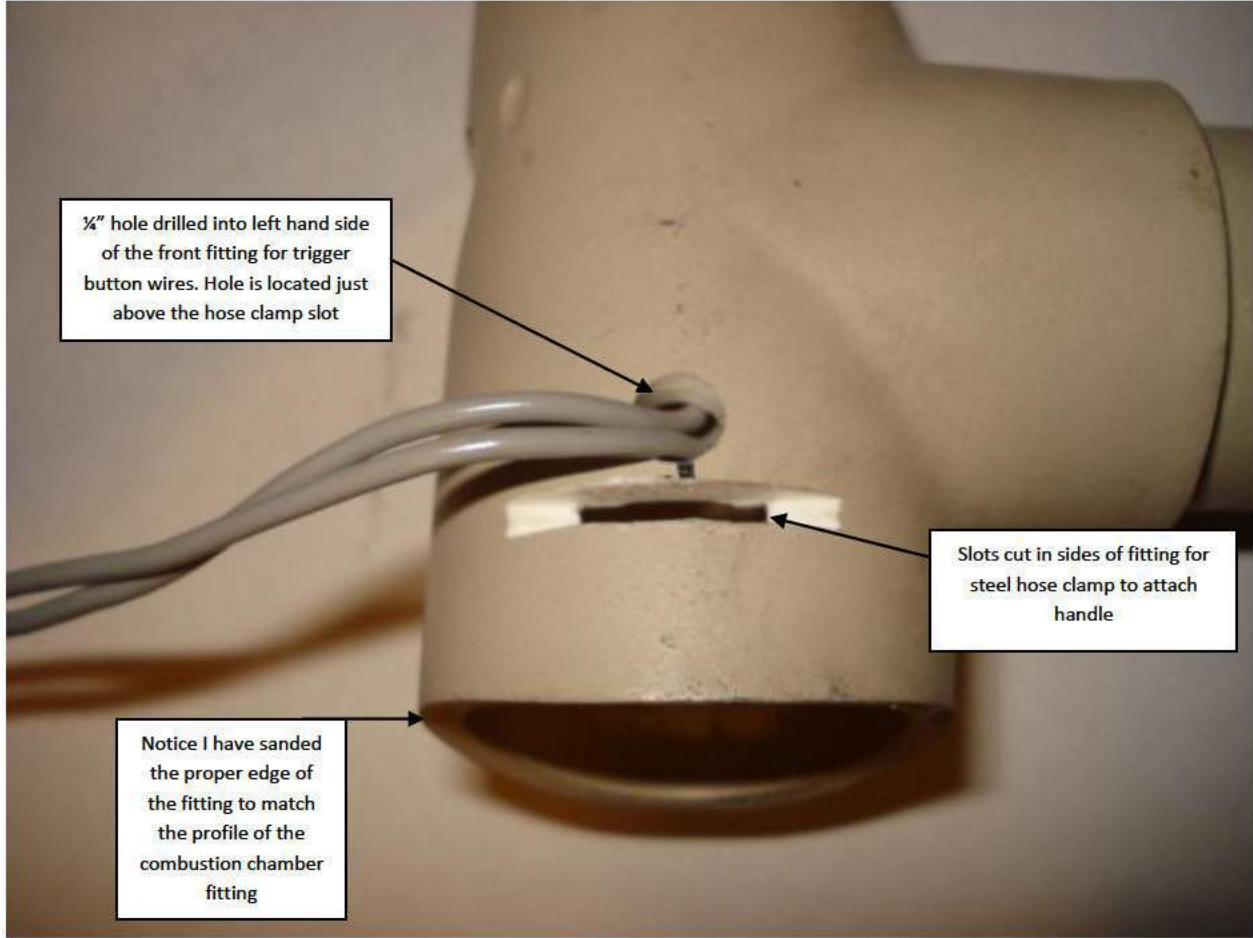

Now you will need to drill the  $\frac{5}{8}$ " hole in the front of the fitting as shown in the photo below to allow for the gas fitting to exit the handle. The top edge of the hole should be about 1" below the top edge of the "T" fitting.

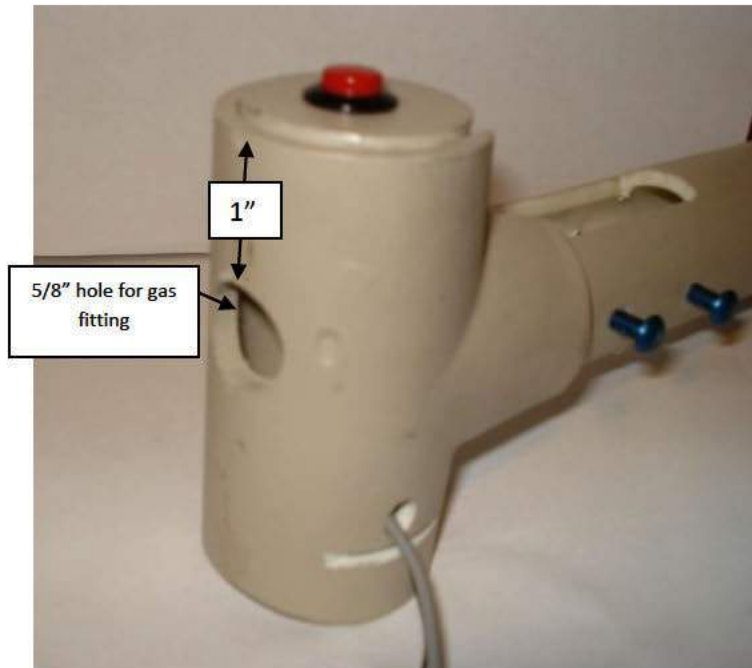

Next is the fabrication of the center section of the handle, it will be constructed of an approximately 7 and 1/2 inch long piece of 3/4 inch PVC pipe. It should be verified that this is the correct length by dry fitting the pieces made above for the handle and ensuring it fits on the combustion chamber as shown in the photo below.



Now that you have the correct length of PVC cut for your handle, you need to create the cutout for the valve, and the bottom Legris swivel fitting, and then drill and tap the holes for mounting the valve. To begin, slide the PVC pipe into the front "T" fitting all the way and mark the depth on the PVC pipe. This

mark will be the front edge of the cutout for the valve. Now mark the cutout shape using the valve, it should be a rectangle as show below. I cut this out using a rotozip spirial cutter, you could use many different tools to create this cutout, this is where you need to get creative. You can drill the hole shown in the bottom of the handle as shown below, or you can use a jigsaw or other tool and cut matching rectangles in the top and bottom of the pipe if this is easier. I made the hole usign a drill press and a 1" forstner bit. This is to allow the bottom gas fitting on the valve to exit the handle. If I were to make another handle, I would just cut matching rectangles through both sides of the pipe as it would be simpler.

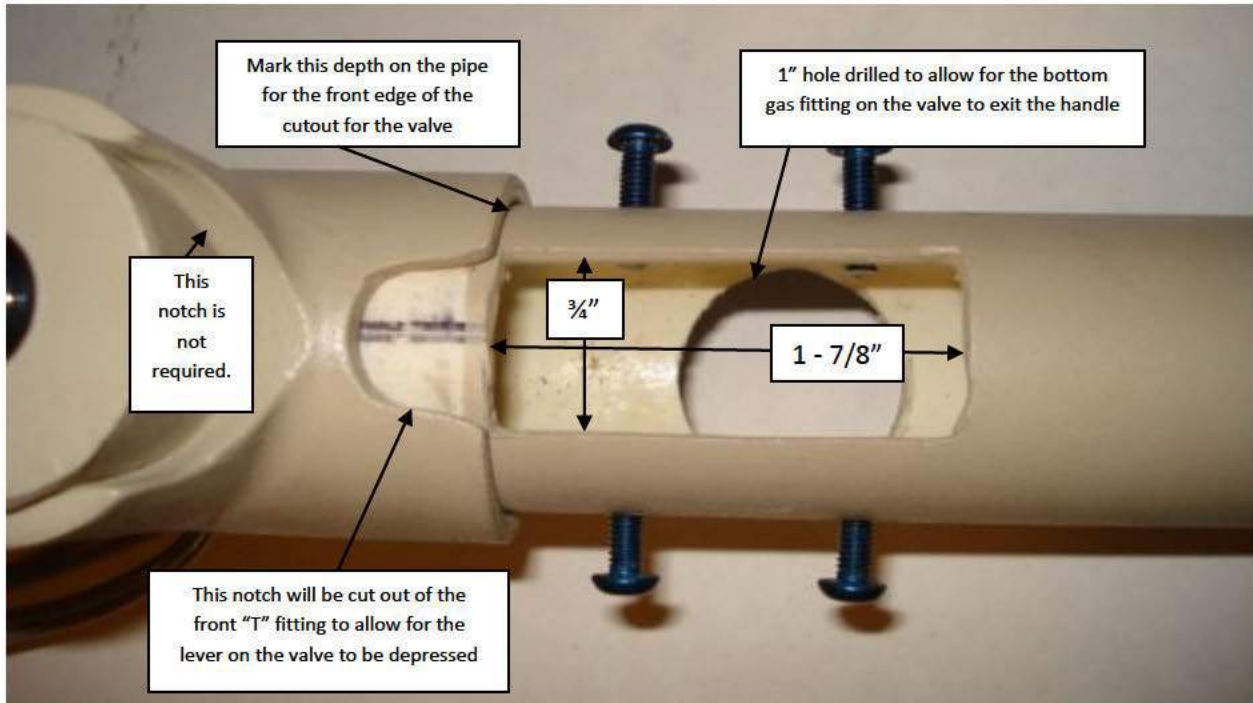

Remember, PVC pipe is cheap if you don't like the first attempt, or second, or.... Just keep trying. I went through a lot of attempts to get everything to my liking.

Once you get a handle created that you like and the valve fits in the cutouts you made, we need to drill 4 holes to mount the valve in the handle. This part will also be difficult, but can be accomplished in many ways. I will explain what I did but you can get the idea of what needs to be done by the photos below. The key is just to ensure the valve is mounted low enough in the PVC pipe to allow the pipes to thread in to the valve, and high enough to allow the lever to still be depressed. See the photos below to better understand what I am describing.

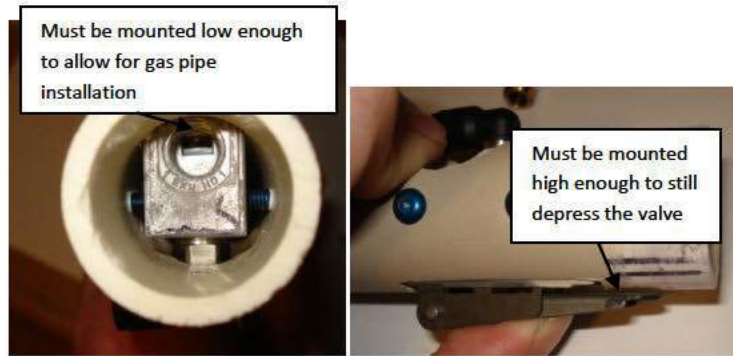

First I secured the PVC pipe in a small vice, or use whatever you can come up with to hold the pipe so that when the valve is inserted in to the cutout as shown below, the top and bottom surfaces are parallel with the table. I then held the valve on the outside of the pipe with the top edge of the valve body flush with the edge of the cutout and marked the holes by using the inside of a ball point pen passed through the holes to mark the pipe. I then drilled holes at these two points all the way through the pipe to create four mounting holes for the valve. You can use several different mounting methods to mount the valve, I tapped the mounting holes in the valve for the four small screws I show mounting the valve, or you can use 2 longer screws that go in one side of the handle, pass through the valve and then screw into the other side of the handle, or many other options. You just need to somehow rigidly mount the valve in the handle similar to the method shown in the photos below.

As I mentioned, this is probably the most difficult parts to fabricate, don't worry, your second try will come out better. If you absolutely cannot construct the handle, contact me via email and you can purchase one from me. Once you get the valve mounted in the pipe as shown in the photos below, go ahead and leave it mounted for the later handle assembly stage. Make sure the bottom legris quick connect fitting is installed in the valve first.



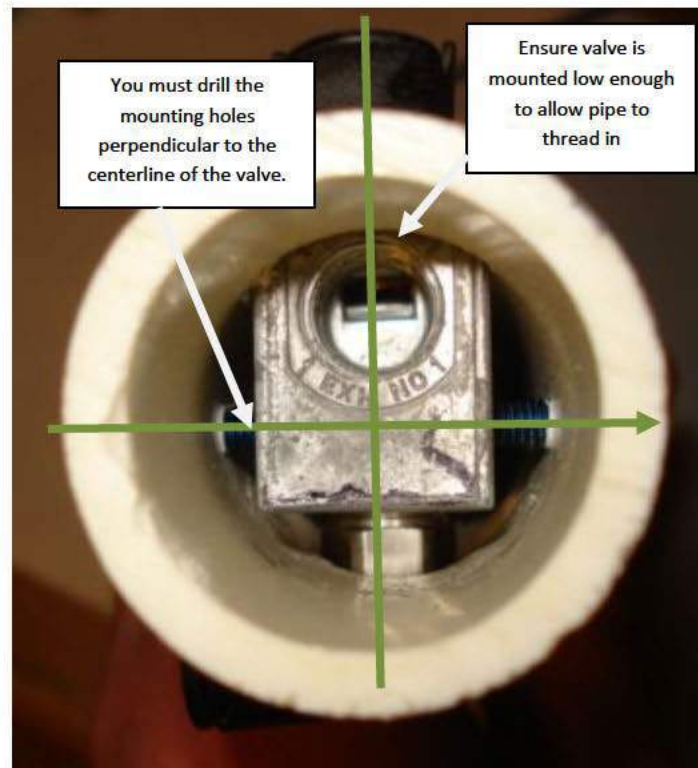
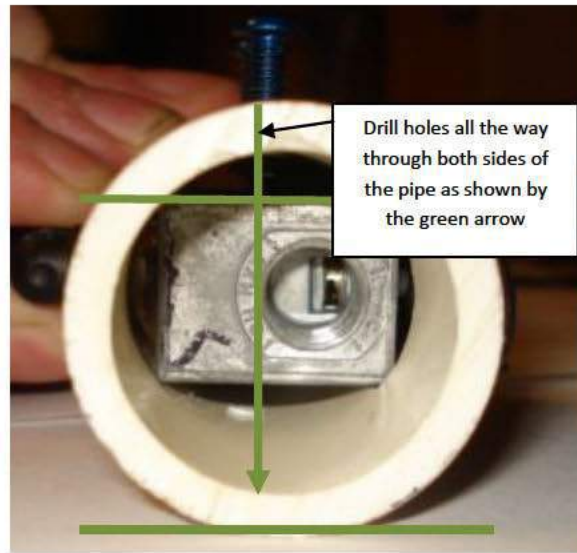

The next and final portion of this section is the fabrication of the trigger assembly. This is constructed of a short section of  $\frac{3}{4}$ " PVC pipe with a piece of steel epoxied to the top of it. I used a circle I cut out of a roof flashing shingle to glue to the top of the PVC pipe, but you could use thin plywood, or whatever you may have lying around that is rigid and that you can cut a circle out of. Cut a circle out of whatever material you choose the same diameter of the  $\frac{3}{4}$ " PVC pipe, then 2-part epoxy this circle to one end of the PVC pipe section. You will then need to drill a hole in the center of the cap the correct diameter for

whatever momentary contact, push button switch you plan to use for the ignition button. Now, solder 16" long speaker wire leads to the switch and insert the switch into the hole as shown in the photos.

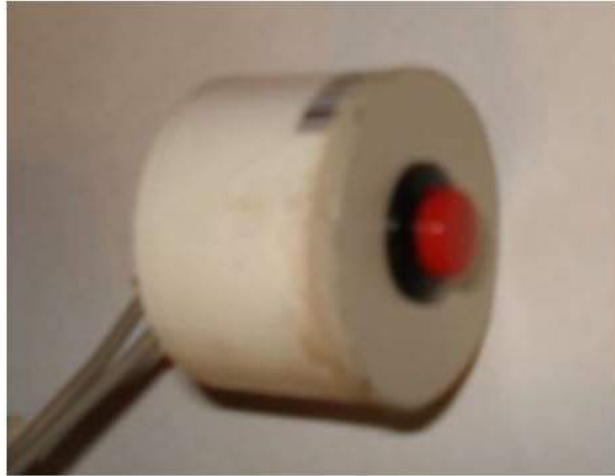

Now we will need to fit the completed handle assembly together and mark the location for the notch in the front "T" fitting to allow for the gas valve handle to be depressed. Mark the location with a marker on the fitting then disassemble the front fitting and cut the notch using a spiral cutter or alternate tool. The notch should look similar to the photo below.

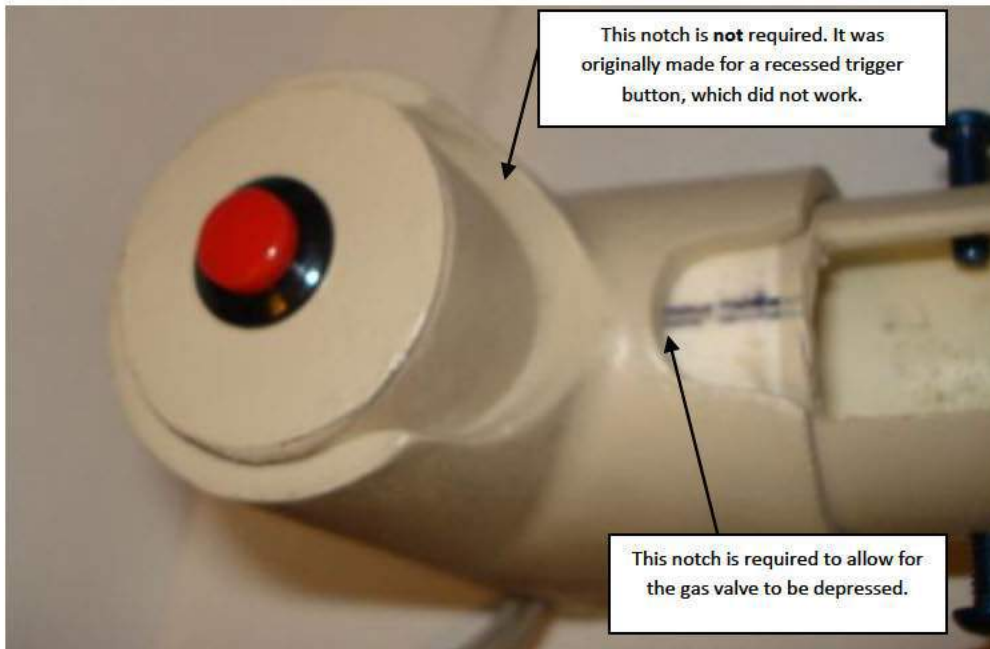

Go ahead and sub-assemble the handle to the level shown in the photo below in order to measure for the pipes that will be needed for the gas system construction in the next section.



This concludes the work on the handle assembly for now; we will resume work with it during the cannon assembly stage. Now is a good time to paint your handle with the color scheme of your choice, if you so wish.

### Gas Metering System Construction:

The gas metering system is based on a Mead MV-10 Three Way Valve. You could probably use another 3-way pneumatic valve, but I found this one to work great. The valve is shown in the photo below.



The gas system begins with measuring the handle built in the previous section, and purchasing the required pipe to make it fit in the handle. It should be constructed such that the ends of the pipes

should protrude from the front and back holes on the handle. The photo below shows the dimensions that I built mine too. Notice that I used several different lengths of pipe coupled together to create the longer pipe, I did this because these were the longest sections they had at my local hardware store. You could construct these with single pieces of pipe if they are available in the required lengths, which you can order from McMaster.com. You will need to have 1/8" FPT X 1/8" FPT bushings on each end to screw the 1/8" MPT legris swivel fittings in to. It works best to size the length of the 1/8" MPT pipes such that the 1/8" FPT X 1/8" FPT bushings just stick out of the holes drilled in the handle for the gas tube, this allows you to use a wrench to tighten the pipe in to the valve when assembling the handle. Be sure to use plenty of teflon tape on the threads to prevent leaks (we will need to check the assembly for leaks with soapy water later).



### Spark Strip Construction:

There are many possible ways to construct the spark strip, I will show two below. The first method is what I used because I have a table saw and I think it would require one to make it. The second method is very easy to make and works great as well.

For the first, you will need to cut a length of  $\frac{1}{2}$ " PVC pipe, approximately 10" long. Then using the fence on a table saw, cut the pipe in half lengthwise. You now have 2 10" long  $\frac{1}{2}$  PVC pipe sections, on one of them you will want to cut a very shallow notch in the length of the pipe to allow for the spark conductor wire to lay in the slot. I did this by setting the depth on the table saw and running the  $\frac{1}{2}$  pipe through the saw to cut the notch about  $\frac{1}{2}$  way through the thickness of the pipe.

You will also need to drill one hole in each end of the PVC, through the center of the slot to allow for mounting. The hole for the back of the combustion chamber end will need to be as close to the end of the pipe as possible to allow clearance for the fan. The spacing of the holes is to be made the same as the spacing of the spark strip studs, inside the combustion chamber. Drill the holes to a diameter large enough to slide over the 10-24 spark strip studs. You will then epoxy sections of 10 to 16 gage solid copper wire in the slot with 2 to 3 gaps in the wire spaced evenly along the length. See the photos below for details.

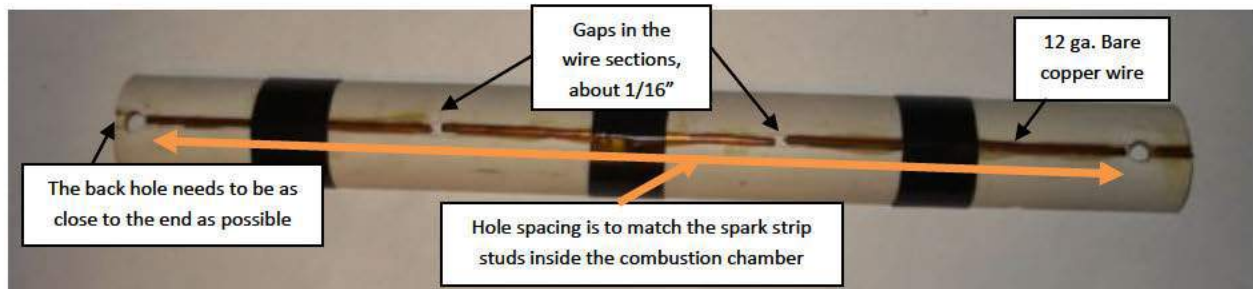

For the second method, you will use a section of small diameter PEX tube, not cut in half, and without the slit for gluing the wire. First, drill holes in the ends of the 10" section of PEX so it will slide on to the spark strip electrodes inside the combustion chamber. Then layout three sections of wire, as with the first method, only this time attach the wires to the tube by wrapping with electrical tape. Don't tape over the gaps or the ends of the wire where the spark strip electrode nuts must touch the wire.

### Forearm Cover Construction (Optional):

The forearm cover is a purely cosmetic option, you can choose if you wish to have one or not. If you do, the design is really up to you. I made mine out of a 9  $\frac{1}{2}$ " long section of 2" PVC (or whatever size slips freely over your barrel). I drilled holes in the PVC in a symmetric pattern; you could do anything you like with this part.

I then drilled and tapped four holes in each end of the PVC pipe to allow for 8-24 mounting screws to clamp it on to the barrel.

It should look similar to the photos below.



#### Front Grip Construction (Optional):

The front grip is also an option, but I highly recommend it. It is constructed if  $\frac{1}{2}$ " PVC pipe and fittings. You will need 4 -  $\frac{1}{2}$ " elbows, 1 -  $\frac{1}{2}$ " "T" fitting, and some  $\frac{1}{2}$ " PVC pipe. I will not go into great detail about the construction, as it should be fairly simple based on looking at the photo below. The only part you will need to fabricate is the "T" fitting used to mount the handle to the barrel. First, profile the bottom edge of the "T" fitting to match your barrel using sandpaper, as you have done before. Then cut notches as also done previously to allow for the hose clamp to pass through the "T" fitting and mount to the barrel. The important part is to know which fittings to glue, and which ones not to glue to be able to assemble the handle and also to allow it to swivel about the "T" fitting. The photo below illustrates the construction of the front grip.

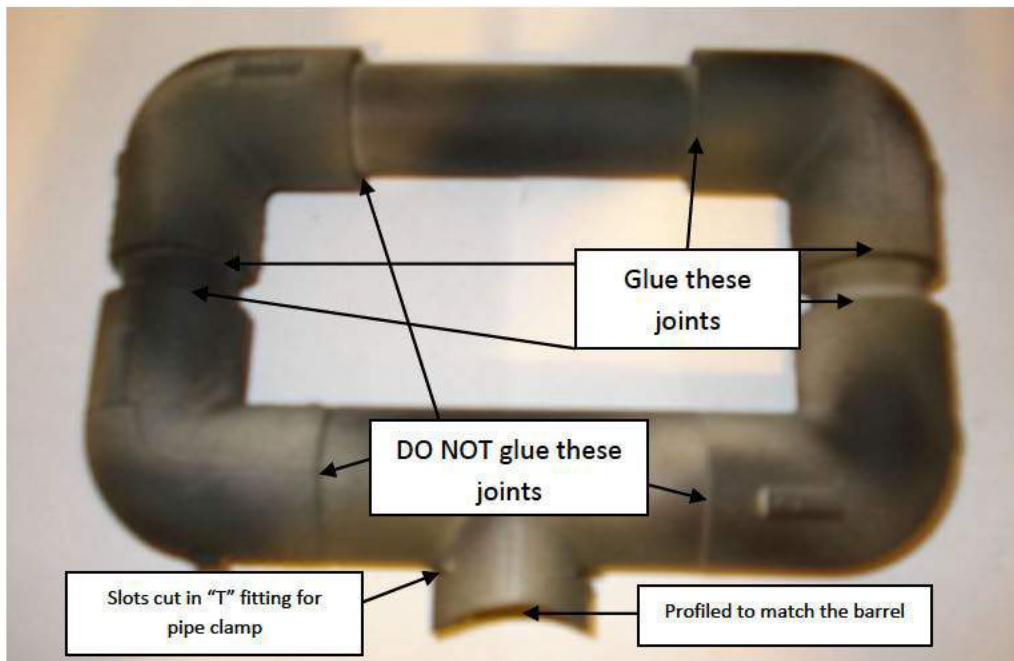

# ASSEMBLY/FITTING STAGE

## Combustion Chamber Assembly:

To assemble the combustion chamber you will need the following parts: 1 - Completed combustion chamber from Construction Stage, 1 - Completed quick vent end cap from Construction Stage, 1 - 1/8" NPT X 1/4" OD tube 90 degree swivel elbow (preferably LEGRIS), 2 - ≈2" long, 10-24 threaded studs, 8 - 10-24 nuts, 2 - ≈1 1/4" long, 8-32 flat head screws, 2 - 8-32 nuts, 1 - combustion chamber fan (brushless computer case fan), 2 - ring terminals for 8-24 studs, and 1 - 3" MPT X 3" female Cam Lock fitting, material of your choice. The photo of the required Cam Lock fitting is shown below.



First, install the gas fitting in the 1/8" FPT hole drilled in the combustion chamber, use Teflon tape on the threads and tighten with a wrench.



Next, install the two 10-24 spark strip studs in to the appropriate holes in each end of the combustion chamber. There should be about 3/8" of stud exposed on the outside of the combustion chamber, just enough for two nuts and a ring terminal. Install the studs to a depth such that they look similar to the photos below. You can set the stud depth using an empty 10-24 ring terminal for now; we will install the leads to the spark strip studs as shown in the photos below during the wiring stage.



Spark strip studs with ring terminal and wire attached (outside of combustion chamber)



Spark strip studs with nut installed to support spark strip (inside of combustion chamber)

Next, install the 8-32 screws in to the appropriate holes in the back of the combustion chamber for the fan. Leave the studs slightly loose to allow for the spade terminals to be slipped under the screws. Layer you will create fan leads by crimping spade terminals to a 16" long piece of two conductor 16 gauge stranded wire, I used speaker wire for this. See photos below for details.



Fan electrode screws

Now we will install the spark strip constructed earlier by clamping it between two nuts as shown in the photos below.



Next, we will install the combustion chamber fan. This is simply a **brushless** computer case fan that measures 3- 1/8" square that will fit inside the combustion chamber. You will have to slightly modify the fan to get it to fit, but this is easily done by cutting the corners off of the fan until it fits in the correct location. I trimmed the edges so that the outside edge of the fan rests on the 4" PVC pipe and the front edge slips inside the 4" PVC pipe. I made this a nice tight fit by adjusting the corners with a file until the fan "locks" in by friction when slid into place. You will also see in the photos below that you will need to crimp small ring terminals to the red and black wires on the fan to attach them to the fan electrodes with 8-24 nuts, install these connectors before installing your fan in the combustion chamber in the wiring stage.





Finally, install the camlock fitting into the front of the combustion chamber, tighten and adjust so that the handles on the camlock fitting are perpendicular to the spark strip studs. I recommend using a small amount of white lithium grease on the threads of the camlock to aid in assembly/removal.

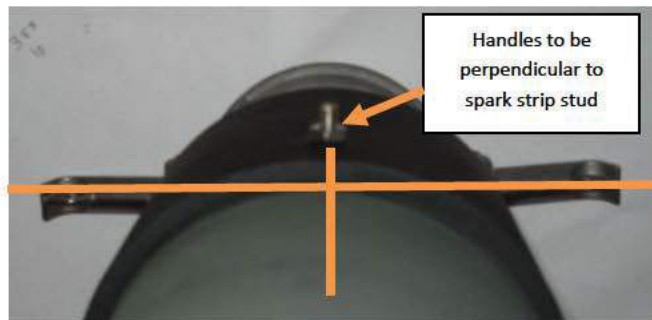

**Barrel Assembly:**

To assemble the barrel you will need the following parts: 1 - Completed barrel from Construction Stage, 1 - Completed forearm cover from Construction Stage (Optional), 1 - Completed front grip from Construction Stage (Optional), 1- Pipe clamp (Optional), and 1 - 3" FPT X 3" female Cam Lock fitting, material of your choice The photo of the required Cam Lock fitting is shown below.



Barrel assembly is quite simple and only involves attaching the camlock fitting to the barrel, attaching the forearm cover, and clamping on the front grip assembly. To clamp the forearm cover on the barrel, you will need to select screw length such that when they are tightened, they just touch the barrel. Start the screws into the threaded holes and slide the forearm cover over the barrel all the way to the breech fitting. Then tighten all 8 screws equally to clamp the forearm cover onto the barrel. Finally, the front grip is then attached to the barrel using a proper sized hose clamp. I used pieces of rubber tube to cover the hose clamp for an improved appearance. The photos below illustrate the assembly of the barrel. I recommend using a small amount of white lithium grease on the threads of the camlocks to aid in assembly/removal.





The completed barrel assembly should resemble the photo below.



## Electronics Pod Assembly:

To assemble the electronics pod you will need the following parts: 1 - Completed electronics pod from Construction Stage, 1 - Electronic Project box, 1 - Spark generator, 1 - Covered safety switch, 1 - small toggle switch, 1 - LED with holder, 2 - 9 volt batteries, and along with these items you will need wire, terminals, heat shrink tubing, etc. I will show you basic wiring diagrams and photos of what I have done, but you may need to come up with some of this on your own. You may wish to not terminate the ends of the wire with connectors until the cannon assembly stage, so you can cut the wires to appropriate lengths before crimping on the terminals. The photos below show the construction of the fan wire harness, and the trigger/safety circuit harness. There is also a sketch of the circuits for your reference.

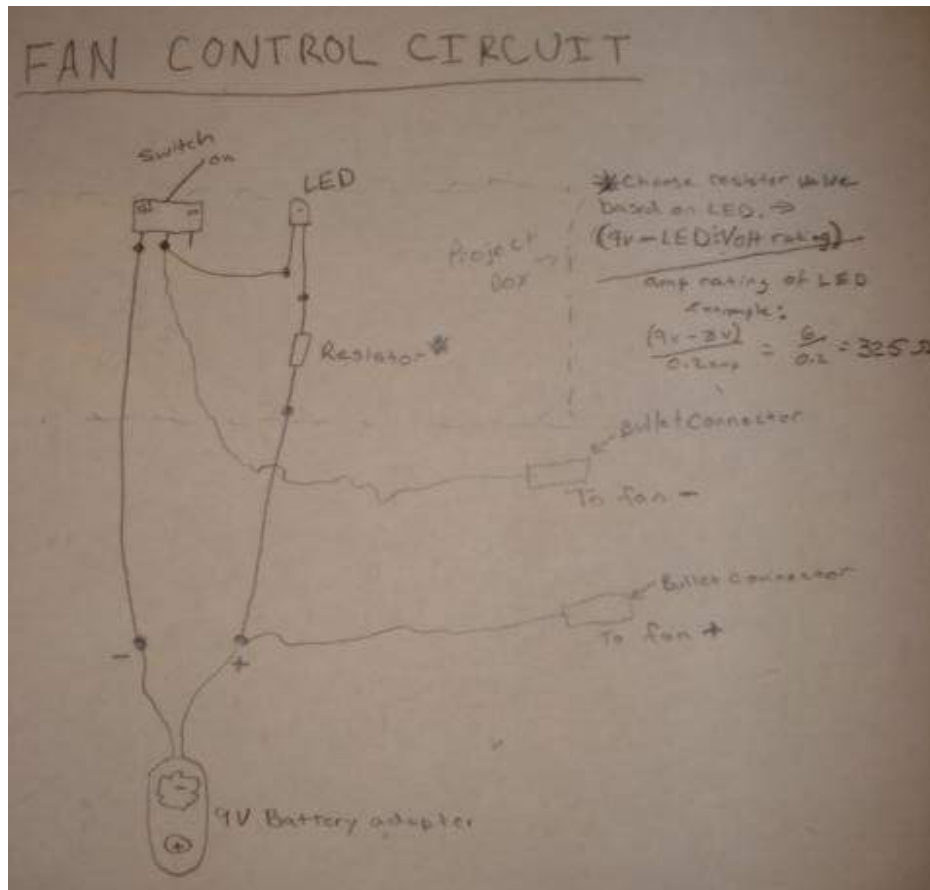
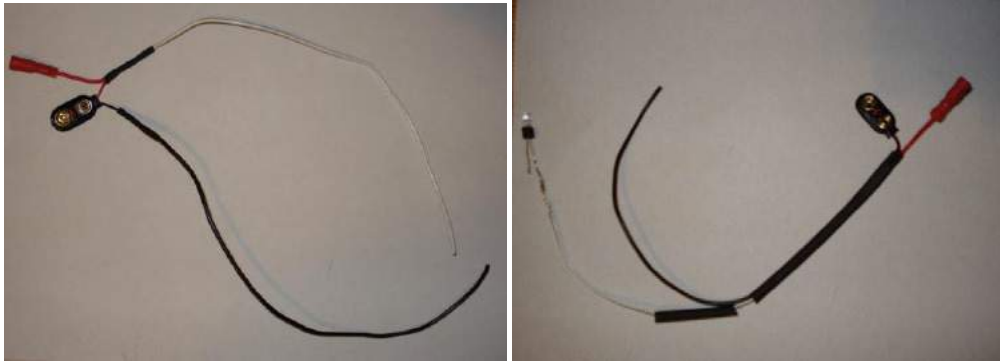

Completed fan harness.

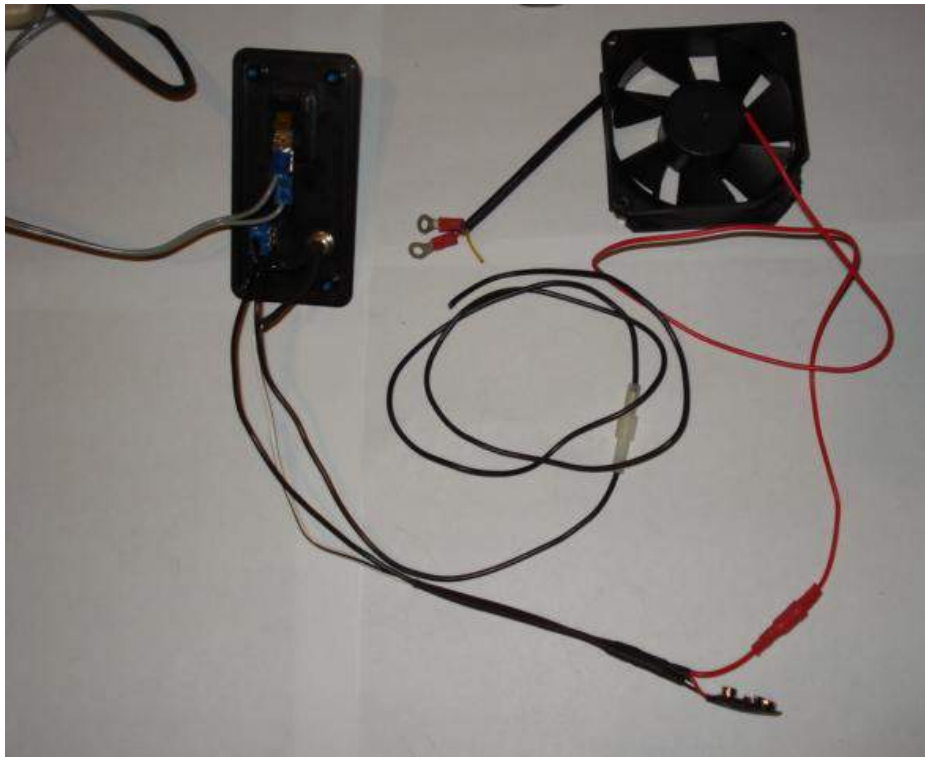
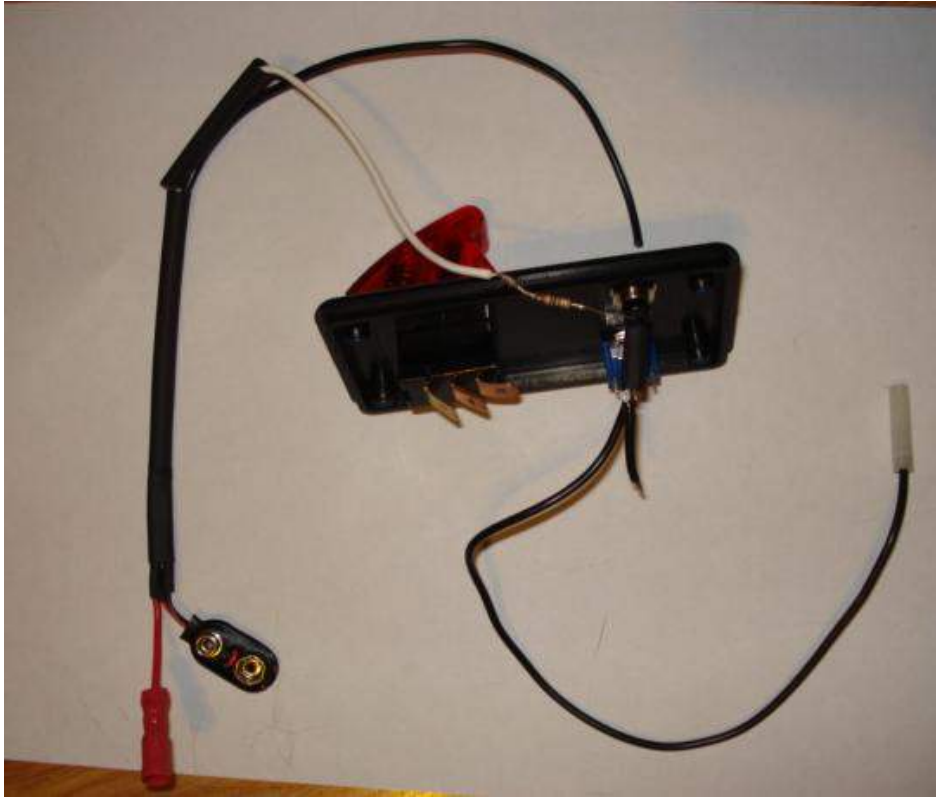

The next photos and drawing show the trigger/safety circuit.



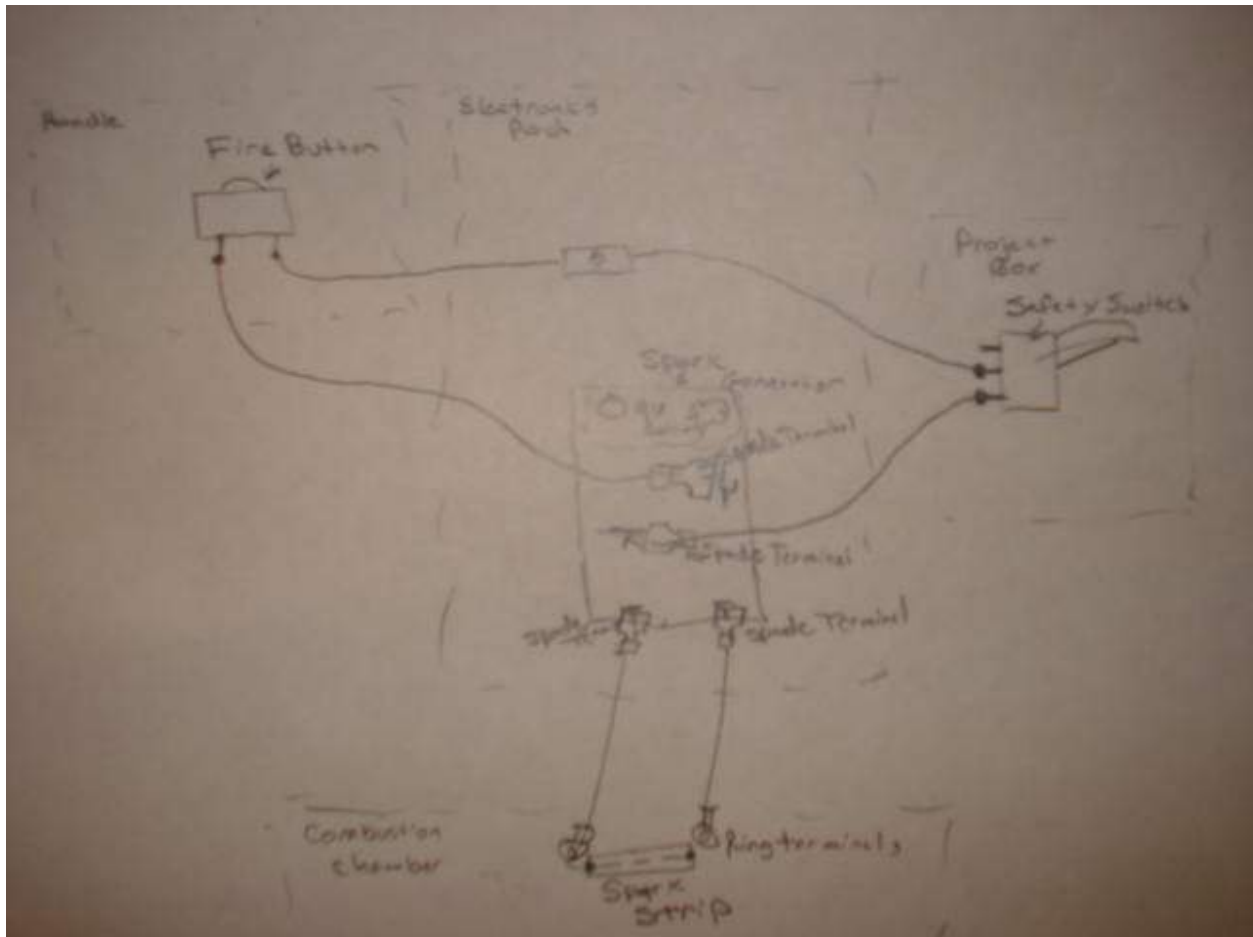

We will now use the harnesses you have prepared above for the cannons final assembly.

### Cannon Final Assembly:

To complete the final assembly of your new potato cannon you will need the following parts: All of the subcomponents you have created in previous stages, 2 – 7 1/8" to 10" Steel worm drive hose clamps, 1 - tall style propane or MAPP gas cylinder, 1 – Propane tank to 1/4" MPT adapter, 1 - 1/4" FPT pressure regulator, 1 - 1/4" MPT to 1/4" OD tube swivel fitting (Legris), 1/4" OD Poly tubing for gas system, heat shrink tubing (5/8" ID) to cover hose clamps (optional), other misc. diameters of heat shrink tubing,

Begin by connecting the spark strip lead ring terminals to the spark strip studs on the combustion chamber, and the fan lead terminals to the fan screws on the combustion chamber, tighten both. Pass the loose ends of the wires into the electronics pod for later connection.

Now we will need to assemble the handle, combustion chamber, gas metering tank and the storage pods in to one unit using the 10" hose clamps. You may also wish to cover your hose clamps with heat shrink tubing at this time. First, pass the hose clamps through the slots on the handle and wrap the clamps around the combustion chamber and pods in a triangular configuration as shown below. Ensure

that the spark strip terminals are on the bottom of the combustion chamber, between the two pods. Once you have it lightly assembled you can insert the gas meter tank at the bottom of the assembly, between the two pods with the swivel fitting towards the back.

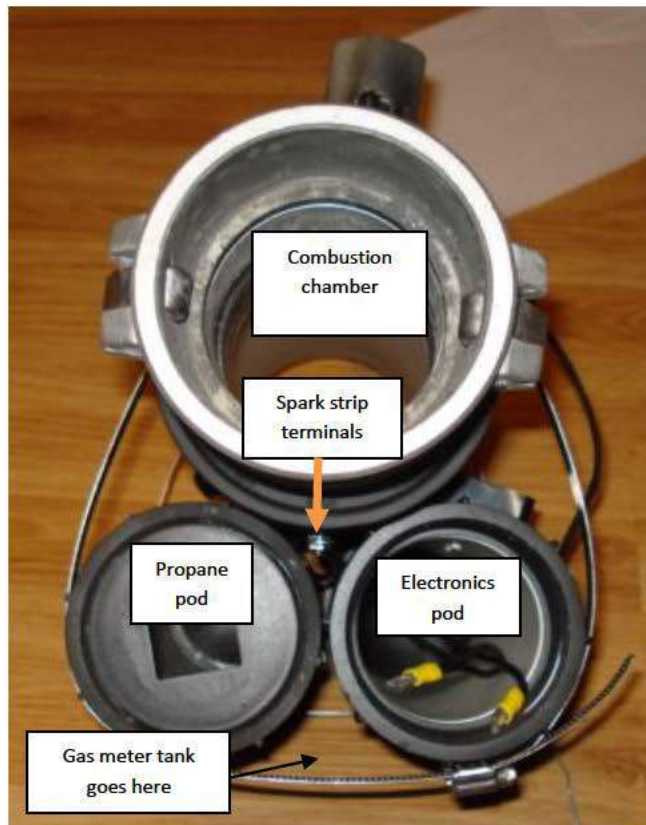



Once you get everything oriented to your satisfaction and all of the wires into the electronics pod, go ahead and tighten the hose clamps. You should now have one solid unit that can easily be carried using the handle.





Next we will place the wired project box cover onto the project box with the proper wires running into the electronics pod. Then, pull all of the wires out of the electronics pod and cut the wire leads to appropriate lengths and terminate the wires with the correct terminals. Finally, complete the wiring connection according to wiring diagrams above and photos below.



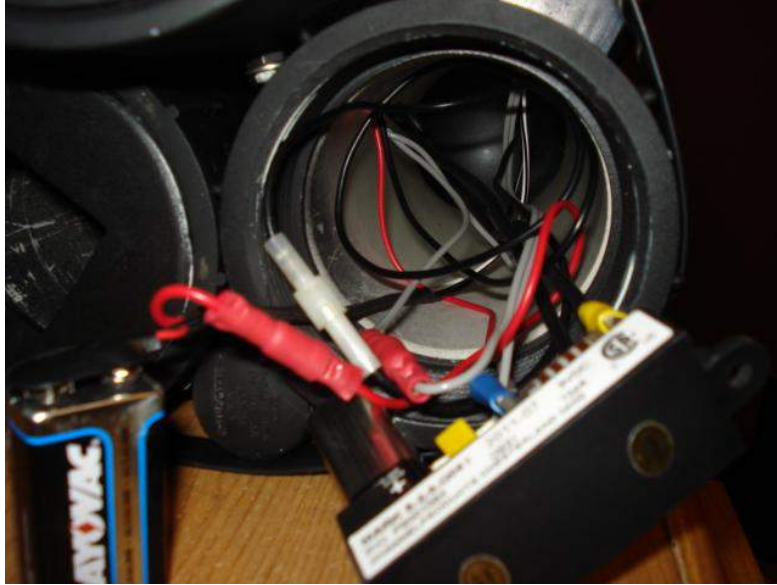



Now we will install the combustion chamber fan. First, install the ring terminals from the fan to the screws inside of the combustion chamber with 8-32 nuts and tighten. Then install the fan into the combustion chamber so that the air flows toward the muzzle end of the chamber.



The wiring diagrams in the above section will help you with the completion of wiring. Once the wires are all connected, test the circuits, then put everything into the electronics pod and lightly screw on the cap.

Finish off the back end of the combustion chamber by screwing in your quick vent end cap, don't over tighten or it will be difficult to remove. Your cannon should now resemble the cannon shown below.



The next step is to complete the gas system. Place the propane pod cap over the propane tank as shown in the photo on the left below. Next you will install the propane tank adapter fitting in to your pressure regulator, be sure to use Teflon tape on the pipe thread fittings. Install the 1/4" MPT to 1/4" quick connect swivel hose fitting into the other side of the pressure regulator. Then screw the propane tank adapter fitting on the propane tank as shown in the right hand photo. The regulator needs to be closed or the propane will flow out.



Next you will slide the propane tank into its pod and screw the cap down far enough to be secure. Cut a piece of your 1/4" OD poly tube the proper length to connect the propane tank to the front swivel fitting on the handle, it should look similar to the photos below



Cut another piece of ¼" OD poly tube the proper length to connect the swivel fitting in the bottom of your valve in the center of the handle to the swivel fitting in the combustion chamber and install the tube. Finally, cut another piece of ¼" OD poly tube the proper length to connect the swivel fitting in the back of the handle to the swivel fitting in the gas meter tank and install the tube. The photos below show the connection of the gas lines.





This completes the assembly of the gas system which should now be tested and checked for leaks. Be sure the safety is on when testing the gas system to avoid possible misfires with propane in the combustion chamber! To check for leaks, spray the fittings with soapy water and watch for bubbles. First, open the regulator until it reads 35 psi and check for leaks, if there are any leaks at this point close the regulator and tighten the leaky fitting. If there are no leaks we can test the operation of the system. Begin by depressing the valve on the handle and holding. You should have heard the propane fill the meter tank to a pressure of 35 psi, you can verify this by reading the pressure off of the regulator, this is the same as the pressure in the meter tank when the valve is held down. Now you will release the valve and this should dump the propane stored in the meter tank into the combustion chamber, you should be able to hear it. If this process works, your gas system is complete.

The final step of cannon assembly is to simply install the barrel using the camlock fitting. Insert the barrel fitting and rotate until the front grip is on the top and pull back the levers on the camlock to lock it in place.



This completes the assembly of your new cannon, sit back and admire it for a minute and get ready to destroy some stuff! In the next and final section I will go over the basic operation of the cannon, and a few safety tips and other ideas.

# Cannon Operation and Safety

## Safety:

First, a few quick items about basic safety:

### NEVER:

- ✦ Point a launcher at people, animals or a non target.
- ✦ Look into the barrel of an unverified launcher.
- ✦ Look into the combustion chamber of an unverified launcher.
- ✦ Check the spark after misfire by looking in the chamber and pulling trigger.
- ✦ If the open chamber catches fire, don't try to blow it out. Just replace the end cap.

### NEVER, NEVER:

- ✦ Use an unsuitable propellant. Acetylene, Oxygen, gunpowder or homemade explosives should never be used in a combustion launcher. Suitable safer propellants should be used such as propane.

The following link is a great source for all sorts of information about combustion launchers; I suggest reading through some of the material here to learn more. <http://www.burntlatke.com/>

## Loading and Firing:

Before beginning the loading process, ensure the safety switch is in the SAFE position to prevent accidental misfires. The first step if firing your cannon for the first time is to load it with a potato. To do this you will need to remove the barrel from the cannon using the camlock fitting. Grab a potato larger than the inside diameter of your barrel, hold it over the sharpened breech end of the barrel and smack it with the palm of your hand. This should create a tight fitting potato slug inside your barrel and trim off the excess material, remove the excess potato and throw it away. You can now re-attach the barrel securely to the cannon using the camlock fitting.

DO NOT point the cannon at anything you do not wish to shoot, the cannon is now loaded and very dangerous! The first thing you will need to do is open the regulator on the propane tank to 35 psi. The next step is to close the quick vent end cap if it is not closed already. Flip the safety switch to the FIRE

position, and turn on the gas mixing fan. Now you will depress the gas valve handle to allow the propane tank to charge the metering tank to 35 psi, you will need to hold it down for about 1 second. After the pressure equalizes and the regulator reaches 35 psi again, you will release the handle on the gas valve to dump the propane from the metering tank into the combustion chamber. Your cannon is now ready to fire.

To fire the cannon, aim it at your intended target and press the red FIRE button... It should go BANG and send the potato rapidly downrange.

If it worked, congratulations! I will now cover the reloading process. If it did not fire, go to the troubleshooting section.

If you are going to reload and fire again, leave the combustion chamber fan running during the process. If you are done firing, go ahead and turn off the combustion chamber fan.

Reload using the following process: Turn the safety switch to the SAFE position, open the quick vent end cap, remove the barrel, load the barrel with fresh ammunition, re-install the barrel, close the quick vent end cap, inject propane by pressing and releasing gas valve, flip the safety switch to the FIRE position, aim and FIRE!

It's as simple as that; you can fire as fast as you can get that process down.

## **Troubleshooting:**

If your cannon did not fire, we will do some simple troubleshooting to determine where the problem lies.

**Before** beginning trouble shooting, turn off propane, remove barrel, open quick vent end cap, and turn on the chamber fan to vent all gas from the chamber.

The first step is to ensure the chamber fan is running; if it is, let it run for several minutes to clear all propane from the combustion chamber, if it is not, locate the problem with the fan and correct it.

The next step is to ensure you have spark in the combustion chamber; NEVER look directly into the combustion chamber when sparking, it could ignite residual gas and burn the S!@\$% out of you. Check for spark with a mirror, or from a distance in a dark room. If you have no spark, find and correct the problem with the spark circuit and continue.

If you have a working fan, and a working spark strip, we need to check for a working propane system. To check this, open the regulator to 35 psi, it should hold steady and not leak. Then press the handle on the gas valve, you should hear the propane fill the meter tank and the pressure should level out at 35psi and not leak. Then you will release the handle on the gas valve and you should hear the propane from the meter tank be injected into the combustion chamber. If one of the steps above did not work as it should, find and correct the problem with the gas injection system.

If the fan, the spark strip, and the gas injection system all work, you probably have a problem with the proper fuel:air ratio. To adjust the fuel:air ratio you will need to adjust the pressure on the regulator until the cannon fires. You need between 2.1% and 9.5% propane to air in order for combustion to occur, with around 4% being optimum. You can adjust it by trial and error until it shoots, or the following link gives a great tool to calculate the gauge pressure required based on the combustion and meter pipe volume. [http://www.burntlatke.com/ft\\_splash.html](http://www.burntlatke.com/ft_splash.html)